

ENVISION™

Geothermal/Water Source Outdoor Split Heat Pumps

- R-410A Refrigerant
- 2, 3, 4, 5, 6 Ton Dual Capacity

Design Features

Factory Options

Accessories

Dimensional Data

Physical Data

Performance Data

Engineering Guide Specifications



Table of Contents

Model Nomenclature	3
ARI Data	3
Design Features	4
NS Split Features	4
Physical Dimensions and Piping Connections	5
Physical Data	6
Air Handlers Compatability	6
Air Handler Coil Data	7
Line Set Sizes	7
Unit Electrical Data	7
Physical Data - Envision Air Handler	8
Model Nomenclature - Envision Coil	9
Refrigerant Compatability	9
Reference Calculations	10
Legends and Notes	10
Performance Data	11-20
Wiring Schematics	21
Microprocessor Control Features and Operation	22-23
Logic Board Physical Layout	23
Engineering Guide Specifications	24
Options & Accessories	24

ENVISION™



Envision Series outdoor splits are designed for either indoor or outdoor installations, and are connected to an indoor air handler via refrigerant lines and control wiring. NS units utilize the ozone-safe R-410A refrigerant to meet the most stringent EPA requirements now and for many years to come. Easily accessible controls and connections for refrigerant piping and water piping make this unit simple to

install in a wide variety of applications. Heavy gauge metal cabinets are coated with durable poly paint for long lasting beauty and protection. For outdoor installations that require an aesthetic touch, an optional decorative rock cover is available in four colors (brown granite, gray granite, salt & pepper, and charcoal basalt). Whether the unit is installed indoors or out, the Envision Series split will provide exceptional performance and comfort for many years. And because there is no outdoor fan like ordinary air conditioners or heat pumps, the NS is “whisper quiet”.

Envision Series units are performance-certified to ARI ISO 13256-1 standards, are ETL Safety listed, and are ENERGYSTAR® qualified.

As a leader in the industry, WaterFurnace is dedicated to innovation, quality and customer satisfaction. In fact, every unit built is exposed to a wide range of quality control procedures throughout the assembly process and is then subjected to a rigorous battery of computerized run tests to certify that it meets or exceeds performance standards for efficiency and safety, and will perform flawlessly at startup. As further affirmation of our quality standards, each unit carries our exclusive Quality Assurance emblem, signed by the final test technician.

WaterFurnace International’s corporate headquarters and manufacturing facility is located in Fort Wayne, IN. A scenic three-acre pond located in front of the building serves as our geothermal heating and cooling source to comfort-condition our 110,000 square feet of manufacturing and office space. As a pioneer, and now a leader in the industry, the team of WaterFurnace engineers, customer support staff and skilled assembly technicians is dedicated to providing the finest comfort systems available.

By choosing or specifying WaterFurnace Envision Series products, you can be assured that your customer is investing in an exceptional comfort system and peace of mind for many years to come.

Model Nomenclature

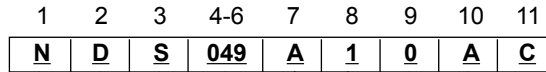

Model Type

N = Envision

Compressor Type

D = Dual Capacity

Cabinet Configuration

S = Outdoor Split

Unit Capacity

Vintage

A = Current

Coax Options

C = Copper

N = Cupronickel

Future Option

A =

Hot Water Option

0 = None

Voltage

1 = 208-230/60/1

Performance Summary

Model	Capacity Modulation	Flow Rate		Water Loop Heat Pump				Ground Water Heat Pump				Ground Loop Heat Pump			
				Cooling Brine EWT 86°F		Heating Brine EWT 68°F		Cooling EWT 59°F		Heating EWT 50°F		Cooling Brine Full Load 77°F Part Load 68°F		Heating Brine Full Load 32°F Part Load 41°F	
		gpm	cfm	Capacity Btuh	EER Btuh/W	Capacity Btuh	COP	Capacity Btuh	EER Btuh/W	Capacity Btuh	COP	Capacity Btuh	EER Btuh/W	Capacity Btuh	COP
026	Full	8	900	25,000	14.6	30,500	5.1	27,800	21.8	25,000	4.6	26,200	17.0	19,500	3.9
	Part	7	700	18,500	16.6	22,000	5.6	21,300	28.4	17,700	4.8	21,000	24.5	16,200	4.4
038	Full	9	1200	34,000	14.6	40,100	5.0	34,300	20.4	33,100	4.5	35,000	17.1	25,700	3.8
	Part	8	800	25,000	16.6	30,000	5.3	25,200	27.0	24,400	4.4	27,000	25.3	22,100	4.2
049	Full	12	1500	45,900	14.0	56,800	4.7	50,500	20.2	46,700	4.4	47,700	16.1	37,000	3.8
	Part	11	1300	35,000	16.2	43,000	5.5	37,300	25.8	33,000	4.7	38,000	22.9	30,500	4.3
064	Full	16	1800	56,300	14.7	67,100	4.6	63,800	19.2	55,800	4.3	59,100	15.5	43,200	3.6
	Part	14	1500	42,900	15.7	49,500	5.1	50,000	24.9	41,000	4.3	47,900	22.2	36,800	3.9
072	Full	18	1800	60,400	13.3	80,600	4.6	67,900	17.8	63,100	3.9	62,700	15.0	50,300	3.4
	Part	16	1600	49,700	14.6	60,200	4.8	57,200	22.8	48,400	4.0	53,800	20.0	42,800	3.8

Notes: Cooling capacities based upon 80.6°F DB, 66.2°F WB entering air temperature.

Heating capacities based upon 68°F DB, 59°F WB entering air temperature.

All ratings based upon operation at the lower voltage of dual voltage rated models.

Refer to the air handler compatability table for matching air handler.

7/21/08



Design Features

Application Flexibility

- Approved for both indoor and outdoor installation.
- Safe, efficient operation in a wide range of liquid temperatures (25° F to 110° F) and flow rates (as low as 1.5 GPM/ton in open loop applications when EWT >50°F).
- Easily accessible loop pump wiring.

Operating Efficiencies

- ARI 13256-1 rating for heating COPs, cooling EERs and low water flow requirements.
- High-stability expansion valve delivers optimum refrigerant flow over a wide range of conditions.
- Efficient Copeland Ultratech compressors provide superior comfort levels.
- Accumulator is on all model for compressor reliability.
- Oversized coaxial tube water-to-refrigerant heat exchanger operates at low liquid pressure drops.
- Convuluted cupronickel water tube functions efficiently at low flow rates, and provides freeze-damage resistance.

Service Advantages

- Easily removable top and cabinet sides. Removable panel for electrical access provides quick access to electrical components.
- Easily accessible thermal expansion valve.
- GeoLink, swivel-type water connections will connect to GeoLink loop pump(s) / 3/4 fpt for open loop application and factory installed P/T ports.
- High- and low-pressure service ports in refrigerant circuit.

Factory Quality

- Heavy-gauge steel cabinets are painted with durable powder coat paint for long lasting beauty and service.
- All refrigerant brazing is performed in a nitrogen atmosphere.
- All units are deep evacuated to less than 150 microns prior to refrigerant charging.
- All joints are helium leak-tested to insure an annual leak rate of less than 1/4 ounce.
- Coaxial heat exchanger, refrigerant suction lines, and all water pipes are fully insulated to reduce condensation problems in low temperature operation.
- Freeze sensing switch to automatically turn on loop pump(s) during off cycle when loop temperature is below 20°F.
- Noise reduction features: isolation mounted compressors; insulated cabinet using 1/2-inch coated glass fiber.
- Safety features include high- and low-pressure refrigerant controls to protect the compressor.

Options & Accessories

- Electronic auto-changeover thermostat with 3-stage heat/2-stage cool and indicator LEDs.
- Closed loop flow center and loop circulating kits.
- Additional accessory relay.
- Bramec III, 6x6 modular mounting pad.
- Decorative rock cover for outdoor use. Available in brown granite, gray granite, salt & pepper, charcoal basalt.

NS Split Features

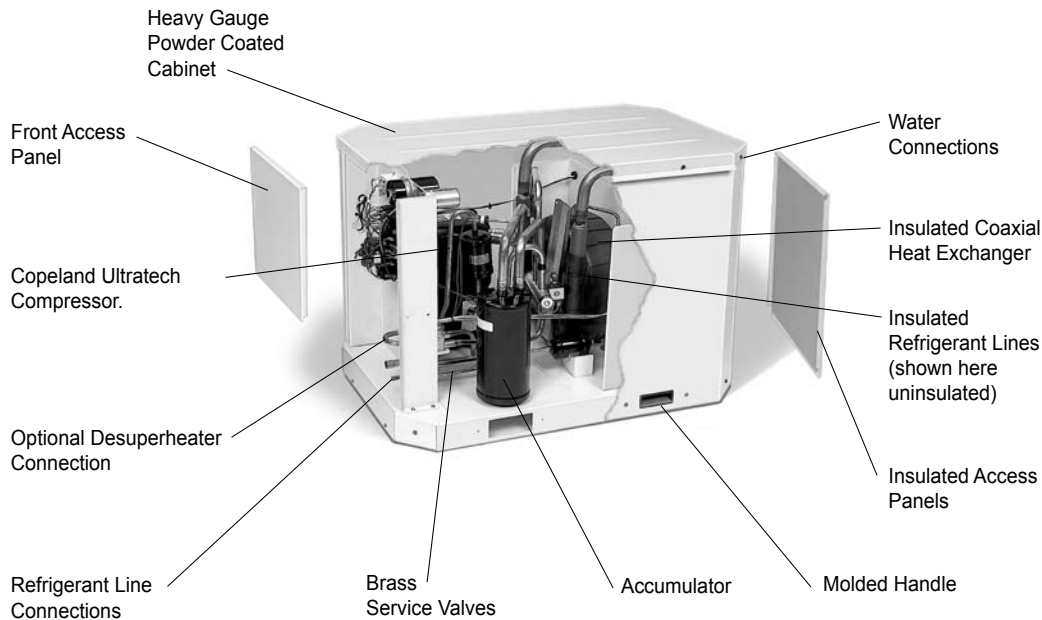

Physical Dimensions and Piping Connections

Cabinet Dimensions and Refrigerant Piping Connections

(Refer to Physical Dimensions table)

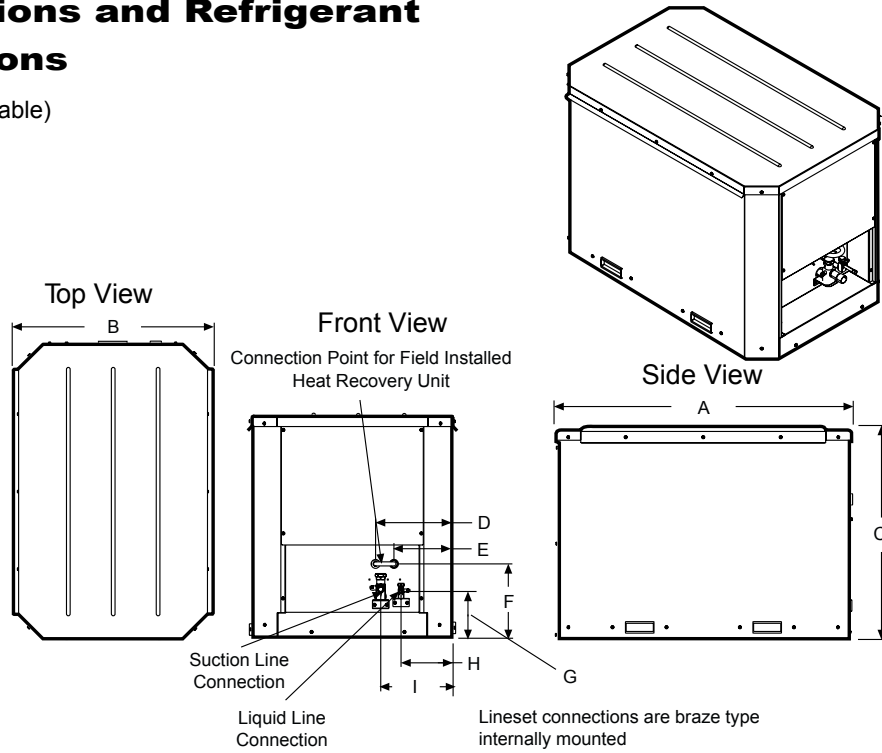

Water Line Locations

(Refer to Physical Dimensions table)

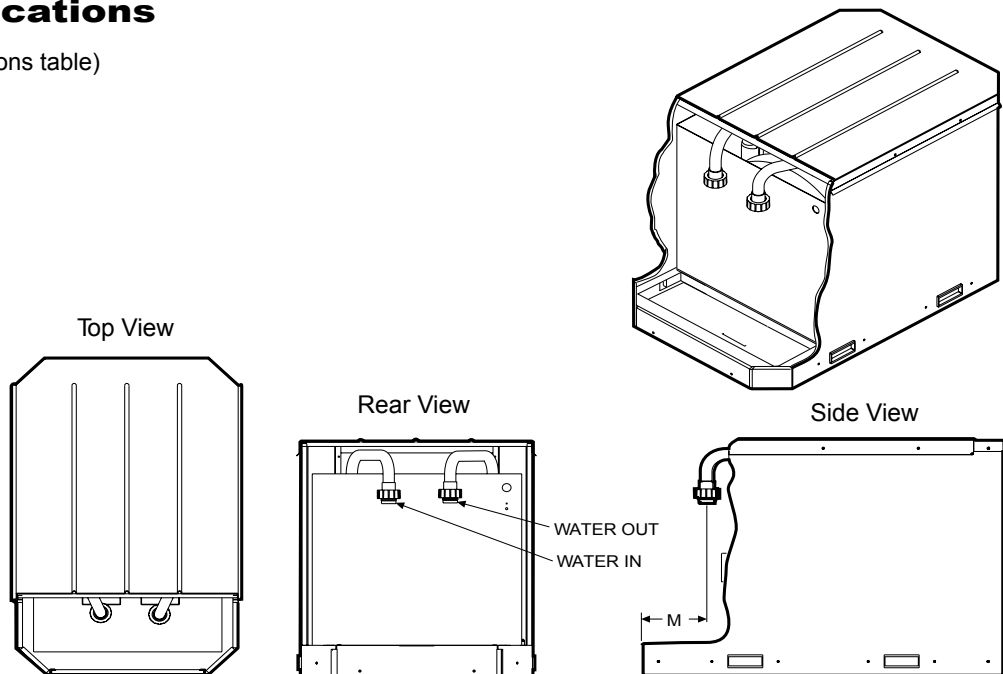

Physical Dimensions

PHYSICAL DIMENSIONS													
MODEL	A	B	C	D	E	F	G	H	I	J	K	L	M
NS026 thru NS072	36.0	23.9	25.7	9.3	7.1	9.0	5.6	8.2	10.7	18.9	8.7	14.8	7.0
	[91.4]	[60.7]	[65.2]	[23.7]	[18.0]	[22.8]	[14.2]	[20.9]	[27.2]	[48.0]	[22.1]	[37.6]	[17.8]

Notes: Refer to Physical Dimensions and Piping Connections drawings
Inches [cm]

Physical Data

MODEL	NS026	NS038	NS046	NS064	NS070
Compressor	Copeland Ultratech Scroll				
Liquid Line Connection*	3/8" [0.95]	3/8" [0.95]	3/8" [0.95]	3/8" [0.95]	3/8" [0.95]
Suction Line Connection	5/8" [1.59]	3/4" [1.90]	3/4" [1.90]	7/8" [2.22]	7/8" [2.22]
Water Inlet/Outlet Size	GeoLink type swivel / Internal 3/4" fpt [2.54] for open loop				
Optional Heat Recovery Connection	1/2" Service Valve [1.27]				
Shipping Weight	240 [109]	287 [130]	312 [142]	354 [161]	359 [163]

Notes: * Line set connections are braze type
Inches [cm], Pounds [Kg]

Air Handlers Compatibility

Air Handler	Split Model (Dual Capacity)	Airflow (CFM)	Electric Heat (kW)
NAH026A***R	NDZ026	925	5
NAH036A***R	NDZ038	1225	5, 10
NAH048A***R	NDZ049	1625	10, 15
NAH060A***R	NDZ064	1760	10, 15, 20
NAH060A***R	NDZ072	1760	10, 15, 20

Air Handler Coil Data

Envision Split Model	Matching Air Handler	Coil Surface Area (sq ft.)	FPI	Rows	Tube Diameter
026 - 038	NAH026-36	5.83	12	2	3/8"
049 - 072	NAH048-060	5.83	12	3	3/8"

Line Set Sizes

Unit Size	Air Handler	20 feet		40 feet		60 feet		Factory Charge (oz.)
		Suction	Liquid	Suction	Liquid	Suction	Liquid	
NDS026	NAH026	5/8" OD	3/8" OD	3/4" OD	3/8" OD	3/4" OD	1/2" OD	52
NDS038	NAH036	5/8" OD	3/8" OD	3/4" OD	3/8" OD	3/4" OD	1/2" OD	56
NDS049	NAH048	3/4" OD	3/8" OD	7/8" OD	3/8" OD	7/8" OD	1/2" OD	90
NDS064	NAH060	7/8" OD	1/2" OD	7/8" OD	1/2" OD	1-1/8" OD	1/2" OD	92
NDS072	NAH060	7/8" OD	1/2" OD	7/8" OD	1/2" OD	1-1/8" OD	1/2" OD	104

Notes: Lineset charge for R410A is 0.50 oz. per ft. for 3/8" and 1.0 oz. per ft. for 1/2" tube.

Rev.: 4/1/08

Initial Total System Charge = Factory Split charge + lineset charge + 20 oz, then adjust charge by subcooling and superheat measurements.

Unit Electrical Data

Model	Rated Voltage	Voltage Min/Max	Compressor			HWA Pump FLA	Ext Loop FLA	Total Unit FLA	Min Circ Amp	Max Fuse/HACR
			MCC	RLA	LRA					
026	208-230/60/1	197/253	16.0	10.2	52.0	0.4	5.4	16.0	18.6	25
038	208-230/60/1	197/253	26.0	16.6	82.0	0.4	5.4	22.4	26.6	40
049	208-230/60/1	197/253	33.0	21.1	96.0	0.4	5.4	26.9	32.2	50
064	208-230/60/1	197/253	40.0	25.6	118.0	0.4	5.4	31.4	37.8	60
072	208-230/60/1	197/253	42.5	27.2	150.0	0.4	5.4	33.0	39.8	60

Rated Voltage of 208-230/60/1.

Rev.: 02/20/07

HACR circuit breaker in USA only.

Min/Max Voltage of 197/253.

All fuses Class RK-5.

Physical Data - Envision Air Handler

Air Handler Model Number (Refrigerant)		NAH022	NAH026	NAH030	NAH036	NAH042	NAH048	NAH060	
Evaporator Coil	Air Coil Total Face Area, ft ² [m ²]	5.83 [0.54]							
	Tube outside diameter - in. [mm]	3/8 [9.52]							
	Number of rows	2			3				
	Fins per inch	12							
	Suction line connection - in. [mm] sweat	5/8 [15.87]				7/8 [22.22]			
	Liquid line connection - in. [mm] sweat	3/8 [9.52]							
Refrigerant		R-410a							
Nominal cooling capacity - tons [kW]		1.8 [6.44]	2.1 [7.59]	2.5 [8.79]	3 [10.55]	3.5 [12.30]	4 [14.06]	5 [17.58]	
Condensate drain connection - (FPT) in. [mm]		3/4 [19.05]							
Blower Wheel Size (Dia x W), in. [mm]		11 x 10 [279 x 254]							
Blower motor type/speeds		ECM variable speed							
Blower motor output - hp [W]		1/2 [373]				1 [746]			
Filter Standard - 1" [51mm] MERV3 disposable, in. [mm]		20 x 24 [508 x 635]							
Electrical characteristics (60hz)		208/230 - 1ph							
Shipping weight - lbs. [kg]		215 [97.52]				220 [99.79]			
Operating weight - lbs. [kg]		195 [88.45]				200 [90.71]			

1/11/08

Air Handler Model Number (Hydronic)		NAH026	NAH036	NAH048	NAH060
Hydronic Coil	Air Coil Total Face Area, ft ² [m ²]	6.94 [0.64]			
	Tube outside diameter - in. [mm]	3/8 [9.52]			
	Number of rows	3			
	Fins per inch	13			
	Water In connection - in. [mm] sweat	7/8 [22.22]			
	Water Out connection - in. [mm] sweat	7/8 [22.22]			
Nominal cooling capacity - tons [kW]		2.1 [7.59]	3 [10.55]	4 [14.06]	5 [17.58]
Condensate drain connection - (FPT) in. [mm]		3/4 [19.05]			
Blower Wheel Size (Dia x W), in. [mm]		11 x 10 [279 x 254]			
Blower motor type/speeds		ECM variable speed			
Blower motor output - hp [W]		1/2 [373]	1 [746]		
Filter Standard - 1" [51mm] MERV3 disposable, in. [mm]		20 x 24 [508 x 635]			
Electrical characteristics (60hz)		208/230 - 1ph			
Shipping weight - lbs. [kg]		220 [99.79]			
Operating weight - lbs. [kg]		200 [90.71]			

3/11/08

NOTE: Water connection dimensions are O.D.

Model Nomenclature - Envision Coil

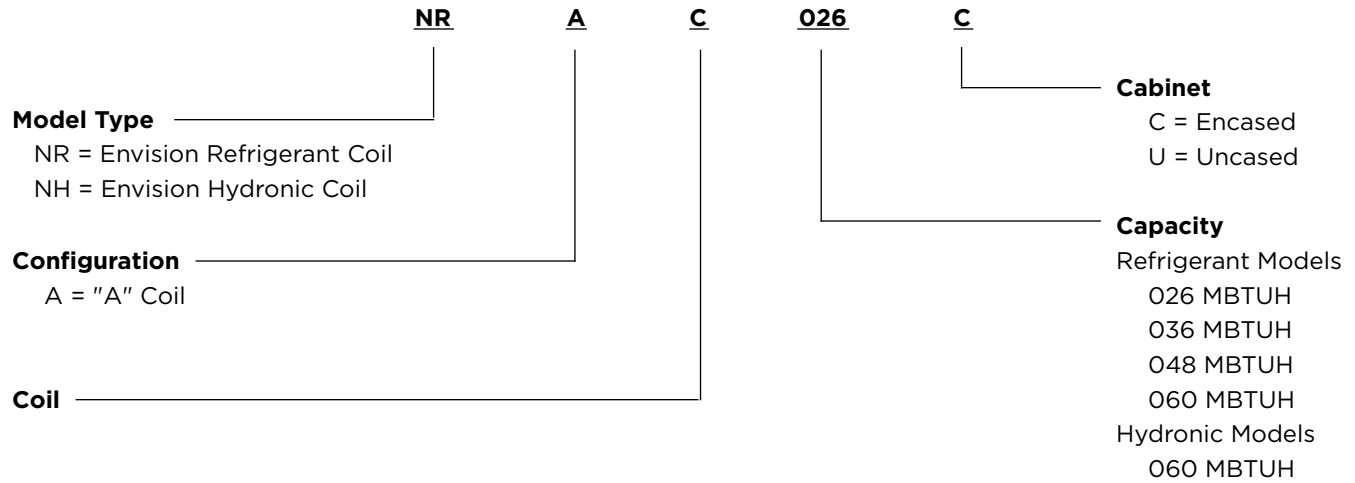

Note: All Refrigerant Coils include TXV. The encased coil cabinet is designed for upflow applications.

Refrigerant Coil Compatibility

Encased/Uncased Coil	Indoor Split Model (Single)	Indoor Split Model (Dual Capacity)	Outdoor Split Model (Dual Capacity)	Recommended Airflow (CFM)
NRAC026*	NSZ022	-		800
NRAC026*	-	NDZ026	NDS026	925
NRAC026*	NSZ030	-	-	980
NRAC036*	NSZ036	-	-	1225
NRAC036*	-	NDZ038	NDS038	1225
NRAC048*	NSZ042	-	-	1425
NRAC048*	NSZ048	-	-	1625
NRAC048*	-	NDZ049	NDS049	1625
NRAC060*	NSZ060	-	-	1760
NRAC060*	-	NDZ064	NDS064	1760
NRAC060*	NSZ070	-	-	1760
NRAC060*	-	NDZ072	NDS072	1760

7/14/08

Reference Calculations

Heating Calculations:	Cooling Calculations:
$LWT = EWT - \frac{HE}{GPM \times 500}$	$LWT = EWT + \frac{HR}{GPM \times 500}$
$LAT = EAT + \frac{HC}{CFM \times 1.08}$	$LAT (DB) = EAT (DB) - \frac{SC}{CFM \times 1.08}$
$TH = HC + HW$	$LC = TC - SC$
	$S/T = \frac{SC}{TC}$

Legends and Notes

ABBREVIATIONS AND DEFINITIONS:

CFM = airflow, cubic feet/minute	HE = total heat of extraction, MBTUH
EWT = entering water temperature, Fahrenheit	HW = desuperheater capacity, MBTUH
GPM = water flow in gallons/minute	EER = Energy Efficient Ratio
WPD = water pressure drop, PSI and feet of water	= BTU output/Watt input
EAT = entering air temperature, Fahrenheit (dry bulb/wet bulb)	COP = Coefficient of Performance
HC = air heating capacity, MBTUH	= BTU output/BTU input
TC = total cooling capacity, MBTUH	LWT = leaving water temperature, °F
SC = sensible cooling capacity, MBTUH	LAT = leaving air temperature, °F
KW = total power unit input, kilowatts	TH = total heating capacity, MBTUH
HR = total heat of rejection, MBTUH	LC = latent cooling capacity, MBTUH
	S/T = sensible to total cooling ratio

Capacity data on pages 11-20 do not include water pumping watts and are based upon 15% (by volume) methanol antifreeze solution. Interpolation between EWT, GPM and CFM data is permissible. Extrapolation for heating data down to 25°F is permissible. Catalog illustrations cover the general appearance of products at time of publication. We reserve the right to make changes in design and construction at any time without notice.

NDS026 - Performance Data

Low Speed (700CFM)

EWT °F	Flow gpm	WPD		HEATING - EAT 70°F							COOLING - EAT 80/67 °F							
		PSI	FT	Airflow cfm	HC kBtuh	Power kW	HE kBtuh	LAT °F	COP	HWC kBtuh	Airflow cfm	TC kBtuh	SC kBtuh	S/T Ratio	Power kW	HR kBtuh	EER	HWC kBtuh
20	3.0	0.8	1.9	Operation not recommended							Operation not recommended							
	5.0	2.0	4.7	Operation not recommended							Operation not recommended							
	7.0	3.7	8.7	500 700	11.3 11.4	1.10 1.11	7.5 7.7	90.9 85.1	3.01 3.03	1.7 1.5	Operation not recommended							
30	3.0	0.8	1.8	Operation not recommended							Operation not recommended							
	5.0	2.0	4.5	500 700	13.0 13.2	1.11 1.12	9.2 9.4	94.0 87.5	3.42 3.46	1.7 1.5	500 700	19.4 19.7	12.9 14.1	0.66 0.71	0.56 0.59	21.3 21.7	34.8 33.5	- -
	7.0	3.6	8.4	500 700	13.2 13.4	1.12 1.13	9.4 9.6	94.5 87.7	3.46 3.48	1.7 1.6	500 700	19.5 20.0	12.9 14.1	0.66 0.70	0.54 0.57	21.3 21.9	36.0 35.1	- -
40	3.0	0.8	1.8	Operation not recommended							Operation not recommended							
	5.0	1.9	4.4	500 700	15.3 15.6	1.12 1.13	11.5 11.8	98.3 90.6	4.00 4.06	1.7 1.6	500 700	20.1 20.5	13.4 14.6	0.67 0.71	0.61 0.64	22.2 22.7	32.8 31.9	- -
	7.0	3.5	8.2	500 700	15.6 15.9	1.13 1.13	11.7 12.0	98.8 91.0	4.02 4.10	1.8 1.6	500 700	20.3 20.7	13.4 14.6	0.66 0.71	0.59 0.62	22.3 22.8	34.1 33.3	- -
50	3.0	0.7	1.7	500 700	16.5 16.9	1.12 1.12	12.7 13.1	100.6 92.3	4.34 4.42	1.8 1.7	500 700	20.5 20.9	13.8 15.0	0.67 0.72	0.72 0.75	23.0 23.5	28.3 27.8	0.6 0.7
	5.0	1.8	4.3	500 700	17.4 17.7	1.14 1.14	13.5 13.8	102.2 93.4	4.46 4.54	1.8 1.7	500 700	20.7 21.1	13.9 15.2	0.67 0.72	0.69 0.72	23.1 23.6	30.1 29.5	0.6 0.6
	7.0	3.4	7.9	500 700	17.6 18.0	1.16 1.15	13.7 14.1	102.6 93.9	4.46 4.60	1.9 1.7	500 700	20.9 21.4	13.9 15.2	0.66 0.71	0.67 0.70	23.2 23.7	31.4 30.7	0.5 0.6
60	3.0	0.7	1.7	500 700	18.7 19.1	1.14 1.12	14.8 15.3	104.6 95.3	4.82 4.98	1.9 1.8	500 700	19.8 20.2	13.5 14.7	0.68 0.73	0.82 0.85	22.6 23.1	24.3 23.8	0.9 0.9
	5.0	1.8	4.1	500 700	19.6 20.1	1.16 1.15	15.6 16.1	106.3 96.6	4.95 5.11	2.0 1.8	500 700	20.0 20.5	13.7 14.9	0.68 0.73	0.77 0.81	22.7 23.2	25.9 25.4	0.8 0.9
	7.0	3.3	7.6	500 700	19.9 20.4	1.18 1.16	15.9 16.5	106.9 97.0	4.96 5.16	2.1 1.9	500 700	20.2 20.6	13.7 14.9	0.67 0.72	0.75 0.78	22.8 23.3	26.9 26.4	0.7 0.8
70	3.0	0.7	1.6	500 700	21.0 21.5	1.15 1.13	17.0 17.6	108.8 98.4	5.34 5.58	2.2 2.0	500 700	19.8 20.2	13.7 14.9	0.69 0.74	0.93 0.97	23.0 23.5	21.3 20.9	1.2 1.2
	5.0	1.7	4.0	500 700	21.9 22.6	1.17 1.16	17.9 18.6	110.5 99.8	5.47 5.71	2.2 2.1	500 700	20.0 20.5	13.8 15.1	0.69 0.74	0.88 0.92	23.0 23.6	22.7 22.3	1.1 1.2
	7.0	3.2	7.4	500 700	22.3 22.9	1.19 1.17	18.3 18.9	111.3 100.3	5.50 5.76	2.3 2.1	500 700	20.2 20.6	13.8 15.1	0.68 0.73	0.86 0.89	23.2 23.7	23.5 23.2	1.0 1.1
80	3.0	0.7	1.6	500 700	22.8 23.4	1.18 1.15	18.7 19.5	112.2 101.0	5.65 5.96	2.4 2.2	500 700	18.7 19.1	13.2 14.3	0.71 0.75	1.07 1.10	22.4 22.9	17.5 17.3	1.6 1.7
	5.0	1.7	3.9	500 700	23.8 24.6	1.21 1.18	19.7 20.5	114.0 102.5	5.77 6.11	2.5 2.3	500 700	18.9 19.3	13.3 14.5	0.71 0.75	1.01 1.04	22.3 22.9	18.7 18.5	1.5 1.6
	7.0	3.1	7.1	500 700	24.2 25.0	1.22 1.19	20.0 20.9	114.8 103.0	5.80 6.15	2.6 2.4	500 700	19.1 19.5	13.3 14.5	0.70 0.75	0.98 1.01	22.4 22.9	19.5 19.2	1.4 1.6
90	3.0	0.7	1.5	500 700	24.7 25.5	1.21 1.17	20.6 21.5	115.7 103.8	5.99 6.38	2.7 2.5	500 700	17.1 17.5	12.5 13.5	0.73 0.77	1.22 1.26	21.3 21.8	14.0 13.9	2.2 2.3
	5.0	1.6	3.7	500 700	25.8 26.7	1.24 1.19	21.5 22.6	117.7 105.3	6.10 6.54	2.8 2.6	500 700	17.3 17.6	12.6 13.7	0.73 0.78	1.16 1.19	21.2 21.7	14.9 14.9	2.0 2.2
	7.0	3.0	6.9	500 700	26.2 27.2	1.25 1.21	21.9 23.0	118.5 105.9	6.12 6.59	2.9 2.7	500 700	17.5 17.8	12.6 13.7	0.72 0.77	1.12 1.16	21.3 21.7	15.7 15.4	1.9 2.1
100	3.0	0.6	1.5	Operation not recommended							Operation not recommended							
	5.0	1.6	3.6	Operation not recommended							Operation not recommended							
	7.0	2.9	6.6	500 700	16.7 17.0	12.5 13.6	0.75 0.80	1.32 1.36	21.2 21.6	12.6 12.5	2.6 2.8	500 700	16.9 17.2	12.5 13.6	0.74 0.79	1.28 1.32	21.2 21.7	13.2 13.0
110	3.0	0.6	1.4	Operation not recommended							Operation not recommended							
	5.0	1.5	3.4	Operation not recommended							Operation not recommended							
	7.0	2.8	6.4	500 700	14.6 14.9	11.5 12.5	0.79 0.84	1.50 1.54	19.7 20.2	9.7 9.7	3.3 3.6	500 700	14.8 15.1	11.5 12.5	0.78 0.83	1.46 1.50	19.7 20.2	10.1 10.0
120	3.0	0.6	1.3	Operation not recommended							Operation not recommended							
	5.0	1.4	3.3	Operation not recommended							Operation not recommended							
	7.0	2.7	6.1	500 700	14.0 14.2	11.4 12.4	0.82 0.87	1.71 1.75	19.8 20.2	8.2 8.1	4.1 4.4	500 700	14.1 14.4	11.4 12.4	0.81 0.86	1.65 1.70	19.7 20.2	8.5 8.5

Multiple Flow Rates (for EWT) are shown in the table above. The lowest flow rate shown is used for geothermal open loop/well water systems with a minimum 50° F. The second flow rate shown is the minimum geothermal closed loop flow rate. The third flow rate shown is optimum for geothermal closed loop and the suggested flow rate for boiler tower applications.

NDS026 - Performance Data

High Speed (900CFM)

EWT °F	Flow gpm	WPD		HEATING - EAT 70°F							COOLING - EAT 80/67 °F												
		PSI	FT	Airflow cfm	HC kBtuh	Power kW	HE kBtuh	LAT °F	COP	HWC kBtuh	Airflow cfm	TC kBtuh	SC kBtuh	S/T Ratio	Power kW	HR kBtuh	EER	HWC kBtuh					
20	4.0	1.4	3.2	Operation not recommended							Operation not recommended												
	6.0	2.9	6.6	Operation not recommended							Operation not recommended												
	8.0	4.8	11.1	700	15.7	1.42	10.9	90.8	3.25	2.0	900	16.0	1.43	11.1	86.4	3.27	1.8						
30	4.0	1.4	3.2	Operation not recommended							Operation not recommended												
	6.0	2.8	6.4	700	18.1	1.46	13.1	93.9	3.63	2.2	700	26.1	17.2	0.66	0.94	29.3	27.9	-					
				900	18.4	1.47	13.4	89.0	3.68	2.0	900	26.5	18.8	0.71	0.99	29.9	26.9	-					
	8.0	4.7	10.8	700	18.4	1.47	13.4	94.4	3.68	2.2	700	26.2	17.2	0.66	0.91	29.3	28.9	-					
				900	18.7	1.48	13.6	89.2	3.69	2.0	900	26.8	18.8	0.70	0.95	30.1	28.2	-					
40	4.0	1.3	3.1	Operation not recommended							Operation not recommended												
	6.0	2.7	6.2	700	21.0	1.52	15.8	97.8	4.06	2.4	700	26.4	17.7	0.67	1.02	29.9	26.0	-					
				900	21.4	1.52	16.2	92.0	4.13	2.2	900	26.9	19.3	0.72	1.07	30.6	25.2	-					
	8.0	4.5	10.4	700	21.4	1.53	16.1	98.3	4.08	2.5	700	26.7	17.7	0.66	0.99	30.0	27.0	-					
				900	21.8	1.53	16.5	92.4	4.16	2.3	900	27.2	19.3	0.71	1.03	30.8	26.4	-					
50	4.0	1.3	3.0	700	22.7	1.55	17.4	100.0	4.28	2.6	700	26.3	17.9	0.68	1.19	30.3	22.2	1.2					
				900	23.1	1.55	17.8	93.8	4.36	2.4	900	26.8	19.5	0.73	1.23	31.0	21.7	1.3					
	6.0	2.6	6.0	700	23.8	1.59	18.4	101.5	4.40	2.7	700	26.5	18.1	0.68	1.13	30.4	23.6	1.1					
				900	24.3	1.59	18.8	95.0	4.48	2.5	900	27.1	19.7	0.73	1.17	31.1	23.1	1.2					
	8.0	4.4	10.1	700	24.2	1.61	18.7	101.9	4.40	2.8	700	26.8	18.1	0.67	1.09	30.5	24.6	1.0					
				900	24.7	1.60	19.3	95.4	4.53	2.6	900	27.4	19.7	0.72	1.14	31.2	24.0	1.2					
60	4.0	1.2	2.9	700	25.5	1.64	19.9	103.7	4.57	3.0	700	26.0	17.8	0.68	1.29	30.4	20.2	1.4					
				900	26.1	1.62	20.6	96.8	4.72	2.7	900	26.5	19.3	0.73	1.34	31.0	19.8	1.5					
	6.0	2.5	5.8	700	26.7	1.67	21.0	105.3	4.69	3.1	700	26.2	17.9	0.68	1.22	30.4	21.5	1.3					
				900	27.4	1.66	21.7	98.2	4.84	2.8	900	26.8	19.5	0.73	1.27	31.1	21.1	1.5					
	8.0	4.2	9.8	700	27.2	1.69	21.4	105.9	4.71	3.1	700	26.5	17.9	0.68	1.19	30.5	22.3	1.3					
				900	27.8	1.67	22.1	98.6	4.89	2.9	900	27.0	19.5	0.72	1.23	31.2	21.9	1.4					
70	4.0	1.2	2.8	700	28.5	1.72	22.6	107.6	4.84	3.3	700	25.6	17.7	0.69	1.43	30.5	17.9	1.8					
				900	29.1	1.69	23.4	100.0	5.06	3.1	900	26.1	19.2	0.74	1.49	31.2	17.6	1.9					
	6.0	2.4	5.6	700	29.7	1.76	23.7	109.3	4.96	3.4	700	25.8	17.8	0.69	1.35	30.5	19.1	1.7					
				900	30.6	1.73	24.7	101.5	5.17	3.2	900	26.4	19.5	0.74	1.41	31.3	18.8	1.8					
	8.0	4.1	9.5	700	30.3	1.78	24.2	110.0	4.99	3.5	700	26.1	17.8	0.68	1.32	30.6	19.8	1.5					
				900	31.1	1.75	25.1	102.0	5.22	3.3	900	26.6	19.5	0.73	1.36	31.3	19.5	1.7					
80	4.0	1.2	2.7	700	31.0	1.83	24.8	111.1	4.98	3.7	700	24.6	17.4	0.71	1.59	30.0	15.5	2.2					
				900	31.9	1.78	25.9	102.9	5.26	3.5	900	25.1	18.9	0.75	1.64	30.7	15.3	2.4					
	6.0	2.4	5.4	700	32.4	1.87	26.0	112.9	5.09	3.8	700	24.8	17.5	0.71	1.50	30.0	16.5	2.1					
				900	33.5	1.82	27.3	104.4	5.39	3.6	900	25.4	19.1	0.75	1.55	30.7	16.4	2.3					
	8.0	4.0	9.2	700	33.0	1.89	26.5	113.6	5.11	4.0	700	25.1	17.5	0.70	1.46	30.1	17.3	1.9					
				900	34.0	1.84	27.8	105.0	5.43	3.7	900	25.6	19.1	0.75	1.51	30.7	17.0	2.1					
90	4.0	1.1	2.6	700	33.7	1.94	27.1	114.6	5.10	4.2	700	23.3	16.8	0.72	1.75	29.3	13.3	2.8					
				900	34.9	1.88	28.5	105.9	5.44	3.9	900	23.9	18.2	0.76	1.81	30.0	13.2	3.0					
	6.0	2.3	5.2	700	35.2	1.98	28.4	116.6	5.20	4.3	700	23.5	17.0	0.72	1.66	29.2	14.2	2.6					
				900	36.4	1.91	29.9	107.5	5.58	4.0	900	24.1	18.5	0.77	1.71	29.9	14.1	2.8					
	8.0	3.8	8.8	700	35.8	2.01	28.9	117.3	5.22	4.4	700	23.9	17.0	0.71	1.60	29.3	14.9	2.4					
				900	37.1	1.94	30.5	108.2	5.61	4.1	900	24.3	18.5	0.76	1.66	29.9	14.6	2.7					
100	4.0	1.1	2.5	Operation not recommended							Operation not recommended												
	6.0	2.2	5.1	Operation not recommended							Operation not recommended												
	8.0	3.7	8.5	700	22.4	16.5	0.74	1.86	28.7	12.0	3.2	900	22.8	17.9	0.78	1.91	29.4	11.9	3.5				
110	4.0	1.0	2.4	Operation not recommended							Operation not recommended												
	6.0	2.1	4.9	Operation not recommended							Operation not recommended												
	8.0	3.5	8.2	700	20.5	15.5	0.76	2.06	27.5	10.0	3.9	900	20.9	16.9	0.81	2.12	28.1	9.9	4.2				
				700	20.7	15.5	0.75	2.00	27.5	10.4	3.6	900	21.1	16.9	0.80	2.06	28.1	10.3	4.0				
120	4.0	1.0	2.3	Operation not recommended							Operation not recommended												
	6.0	2.0	4.7	Operation not recommended							Operation not recommended												
	8.0	3.4	7.9	700	19.0	14.9	0.79	2.31	26.8	8.2	4.7	900	19.3	16.2	0.84	2.37	27.4	8.2	5.1				
				700	19.1	14.9	0.78	2.23	26.7	8.6	4.4	900	19.5	16.2	0.83	2.30	27.4	8.5	4.8				

Multiple Flow Rates (for EWT) are shown in the table above. The lowest flow rate shown is used for geothermal open loop/well water systems with a minimum 50° F. The second flow rate shown is the minimum geothermal closed loop flow rate. The third flow rate shown is optimum for geothermal closed loop and the suggested flow rate for boiler tower applications.

NDS038 - Performance Data

Low Speed (1050CFM)

EWT °F	Flow gpm	WPD		HEATING - EAT 70°F							COOLING - EAT 80/67 °F							
		PSI	FT	Airflow cfm	HC kBtuh	Power kW	HE kBtuh	LAT °F	COP	HWC kBtuh	Airflow cfm	TC kBtuh	SC kBtuh	S/T Ratio	Power kW	HR kBtuh	EER	HWC kBtuh
20	4.0	0.9	2.1	Operation not recommended							Operation not recommended							
	6.0	1.7	4.0	Operation not recommended							Operation not recommended							
	8.0	2.9	6.7	900 1050	15.5 16.1	1.47 1.50	10.5 11.0	85.9 84.2	3.10 3.15	2.5 2.2								
30	4.0	0.9	2.0	Operation not recommended							Operation not recommended							
	6.0	1.7	3.9	900 1050	17.2 17.9	1.45 1.49	12.3 12.8	87.7 85.8	3.48 3.53	2.4 2.2	900 1050	26.6 27.3	16.8 18.6	0.63 0.68	0.73 0.74	29.1 29.8	36.5 36.8	- -
	8.0	2.8	6.5	900 1050	18.3 19.1	1.49 1.53	13.2 13.9	88.8 86.8	3.61 3.66	2.5 2.2	900 1050	27.0 27.8	17.3 19.1	0.64 0.69	0.72 0.74	29.5 30.3	37.4 37.7	- -
40	4.0	0.8	1.9	Operation not recommended							Operation not recommended							
	6.0	1.6	3.8	900 1050	20.3 21.0	1.48 1.51	15.3 15.9	90.9 88.6	4.03 4.09	2.5 2.3	900 1050	27.7 28.4	18.0 19.9	0.65 0.70	0.79 0.80	30.4 31.2	35.1 35.3	- -
	8.0	2.7	6.3	900 1050	21.4 22.2	1.51 1.54	16.3 16.9	92.0 89.5	4.15 4.21	2.6 2.3	900 1050	28.1 28.9	18.5 20.4	0.66 0.71	0.78 0.80	30.8 31.6	35.9 36.2	- -
50	4.0	0.8	1.9	900 1050	22.4 23.1	1.50 1.53	17.3 17.9	93.0 90.4	4.36 4.44	2.6 2.4	900 1050	28.6 29.4	19.3 21.3	0.67 0.73	0.90 0.92	31.6 32.5	31.8 32.1	0.9 1.0
	6.0	1.6	3.7	900 1050	23.2 23.9	1.51 1.52	18.0 18.7	93.9 91.1	4.51 4.59	2.7 2.4	900 1050	28.8 29.6	19.4 21.5	0.67 0.72	0.88 0.89	31.8 32.7	33.0 33.2	0.8 0.9
	8.0	2.6	6.1	900 1050	24.3 25.0	1.54 1.56	19.0 19.7	95.0 92.0	4.62 4.70	2.7 2.5	900 1050	29.3 30.1	19.9 22.0	0.68 0.73	0.87 0.88	32.3 33.1	33.8 34.1	0.8 0.9
60	4.0	0.8	1.8	900 1050	25.3 25.9	1.53 1.54	20.0 20.6	96.0 92.8	4.83 4.91	2.8 2.6	900 1050	27.4 28.2	18.6 20.6	0.68 0.73	1.00 1.02	30.9 31.7	27.3 27.6	1.2 1.3
	6.0	1.5	3.6	900 1050	26.3 26.9	1.53 1.54	21.1 21.6	97.0 93.7	5.03 5.12	2.9 2.7	900 1050	27.7 28.5	18.7 20.7	0.67 0.73	0.98 1.00	31.0 31.9	28.3 28.5	1.1 1.2
	8.0	2.5	5.9	900 1050	27.2 27.8	1.57 1.57	21.8 22.4	98.0 94.5	5.09 5.18	3.0 2.7	900 1050	28.1 28.9	19.2 21.2	0.68 0.73	0.97 0.99	31.5 32.3	29.0 29.3	1.1 1.2
70	4.0	0.8	1.8	900 1050	28.0 28.6	1.56 1.56	22.7 23.3	98.9 95.2	5.27 5.37	3.1 2.9	900 1050	27.1 27.8	18.8 20.8	0.69 0.75	1.14 1.16	31.0 31.8	23.8 24.0	1.7 1.8
	6.0	1.5	3.5	900 1050	29.3 29.8	1.55 1.55	24.0 24.5	100.1 96.3	5.52 5.63	3.2 3.0	900 1050	27.3 28.1	18.9 21.0	0.69 0.75	1.11 1.13	31.1 32.0	24.7 24.9	1.6 1.7
	8.0	2.5	5.7	900 1050	30.0 30.6	1.59 1.58	24.6 25.2	100.9 96.9	5.55 5.65	3.3 3.1	900 1050	27.8 28.6	19.4 21.5	0.70 0.75	1.10 1.12	31.5 32.4	25.3 25.5	1.5 1.6
80	4.0	0.7	1.7	900 1050	30.7 31.1	1.59 1.58	25.3 25.7	101.6 97.4	5.66 5.77	3.5 3.3	900 1050	26.1 26.8	18.4 20.4	0.71 0.76	1.30 1.32	30.5 31.3	20.1 20.3	2.3 2.5
	6.0	1.4	3.3	900 1050	32.2 32.6	1.58 1.57	26.8 27.2	103.1 98.7	5.97 6.09	3.6 3.3	900 1050	26.3 27.0	18.6 20.5	0.71 0.76	1.26 1.29	30.6 31.4	20.8 21.0	2.2 2.4
	8.0	2.4	5.5	900 1050	32.6 33.0	1.61 1.60	27.1 27.5	103.6 99.1	5.93 6.05	3.7 3.4	900 1050	26.7 27.5	19.0 21.1	0.71 0.77	1.25 1.28	31.0 31.8	21.4 21.5	2.0 2.2
90	4.0	0.7	1.6	900 1050	33.3 33.6	1.62 1.60	27.8 28.1	104.3 99.6	6.04 6.16	4.0 3.7	900 1050	24.2 24.8	17.2 19.1	0.71 0.77	1.48 1.50	29.2 30.0	16.4 16.5	3.1 3.3
	6.0	1.4	3.2	900 1050	35.0 35.2	1.60 1.58	29.5 29.8	106.0 101.1	6.41 6.54	4.1 3.8	900 1050	24.4 25.1	17.3 19.2	0.71 0.77	1.44 1.47	29.3 30.1	17.0 17.1	2.9 3.1
	8.0	2.3	5.3	900 1050	35.2 35.3	1.63 1.61	29.6 29.8	106.2 101.2	6.31 6.44	4.2 3.9	900 1050	24.8 25.5	17.8 19.7	0.72 0.77	1.43 1.45	29.6 30.4	17.4 17.5	2.7 3.0
100	4.0	0.7	1.6	Operation not recommended							Operation not recommended							
	6.0	1.3	3.1	Operation not recommended							Operation not recommended							
	8.0	2.2	5.1	Operation not recommended							Operation not recommended							
110	4.0	0.7	1.5	Operation not recommended							Operation not recommended							
	6.0	1.3	3.0	Operation not recommended							Operation not recommended							
	8.0	2.1	4.9	Operation not recommended							Operation not recommended							
120	4.0	0.6	1.5	Operation not recommended							Operation not recommended							
	6.0	1.2	2.9	Operation not recommended							Operation not recommended							
	8.0	2.0	4.7	Operation not recommended							Operation not recommended							

Multiple Flow Rates (for EWT) are shown in the table above. The lowest flow rate shown is used for geothermal open loop/well water systems with a minimum 50° F. The second flow rate shown is the minimum geothermal closed loop flow rate. The third flow rate shown is optimum for geothermal closed loop and the suggested flow rate for boiler tower applications.

NDS038 - Performance Data

High Speed (1250CFM)

EWT °F	Flow gpm	WPD		HEATING - EAT 70°F							COOLING - EAT 80/67 °F														
		PSI	FT	Airflow cfm	HC kBTuh	Power kW	HE kBTuh	LAT °F	COP	HWC kBTuh	Airflow cfm	TC kBTuh	SC kBTuh	S/T Ratio	Power kW	HR kBTuh	EER	HWC kBTuh							
20	5.0	1.3	3.0	Operation not recommended							Operation not recommended														
	7.0	2.3	5.2	Operation not recommended							Operation not recommended														
	9.0	3.5	8.1	1050	22.1	2.12	14.9	89.5	3.06	2.8	1250	22.9	2.18	15.4	86.9	3.07	2.5								
30	5.0	1.2	2.9	Operation not recommended							Operation not recommended														
	7.0	2.2	5.1	1050	25.5	2.16	18.1	92.5	3.46	3.0	1250	26.2	2.23	18.7	89.4	3.46	2.8	1050	34.5	20.5	0.59	1.47	39.5	23.5	-
	9.0	3.4	7.9	1050	25.9	2.18	18.5	92.9	3.48	3.1	1250	26.8	2.25	19.1	89.8	3.49	2.8	1050	34.7	22.5	0.65	1.42	39.6	24.4	-
40	5.0	1.2	2.8	Operation not recommended							Operation not recommended														
	7.0	2.1	4.9	1050	29.8	2.29	22.0	96.3	3.81	3.4	1250	30.7	2.34	22.7	92.7	3.85	3.1	1050	35.8	21.9	0.61	1.62	41.4	22.1	-
	9.0	3.3	7.6	1050	30.4	2.31	22.5	96.8	3.85	3.5	1250	31.3	2.36	23.3	93.2	3.89	3.2	1050	36.1	23.8	0.66	1.57	41.5	23.0	-
50	5.0	1.2	2.7	1050	32.3	2.35	24.3	98.5	4.03	3.6	1250	33.2	2.38	25.1	94.6	4.10	3.4	1050	36.0	22.8	0.63	1.92	42.6	18.8	1.7
	7.0	2.1	4.8	1050	33.4	2.40	25.3	99.5	4.09	3.8	1250	34.5	2.43	26.2	95.6	4.16	3.5	1050	36.8	23.1	0.63	1.81	43.0	20.4	1.6
	9.0	3.2	7.4	1050	34.2	2.42	25.9	100.2	4.14	3.9	1250	35.3	2.45	26.9	96.1	4.21	3.5	1050	37.2	24.7	0.66	1.76	43.2	21.1	1.5
60	5.0	1.1	2.6	1050	35.6	2.46	27.2	101.4	4.24	4.1	1250	36.7	2.48	28.3	97.2	4.35	3.8	1050	35.7	23.4	0.66	2.04	42.6	17.4	2.1
	7.0	2.0	4.6	1050	37.2	2.53	28.6	102.8	4.31	4.2	1250	38.4	2.55	29.7	98.4	4.42	3.9	1050	37.4	26.0	0.70	2.14	44.7	17.5	2.2
	9.0	3.1	7.2	1050	38.1	2.56	29.4	103.6	4.36	4.4	1250	39.3	2.57	30.6	99.1	4.49	4.0	1050	36.5	23.6	0.65	1.94	43.1	18.8	2.0
70	5.0	1.1	2.5	1050	39.0	2.59	30.1	104.4	4.40	4.6	1250	40.3	2.59	31.5	99.9	4.56	4.3	1050	36.9	24.9	0.68	1.89	43.3	19.5	1.8
	7.0	1.9	4.5	1050	41.0	2.68	31.8	106.1	4.48	4.7	1250	42.3	2.68	33.2	101.3	4.63	4.4	1050	37.2	27.6	0.71	1.98	45.4	19.5	2.0
	9.0	3.0	6.9	1050	42.0	2.71	32.8	107.1	4.54	4.9	1250	43.5	2.70	34.3	102.2	4.72	4.5	1050	38.2	26.2	0.69	2.02	45.1	18.9	2.1
80	5.0	1.1	2.5	1050	41.5	2.70	32.3	106.6	4.50	5.2	1250	42.9	2.68	33.8	101.8	4.70	4.8	1050	38.7	25.7	0.66	1.90	45.2	20.4	1.8
	7.0	1.9	4.3	1050	43.9	2.81	34.3	108.7	4.58	5.3	1250	45.4	2.78	35.9	103.6	4.78	4.9	1050	37.2	27.4	0.74	2.37	45.3	15.6	3.1
	9.0	2.9	6.7	1050	45.1	2.84	35.4	109.8	4.65	5.5	1250	46.7	2.80	37.1	104.6	4.88	5.1	1050	35.7	23.4	0.66	2.04	42.6	17.4	2.1
90	5.0	1.0	2.4	1050	44.0	2.82	34.4	108.8	4.57	5.8	1250	45.6	2.78	36.1	103.8	4.81	5.3	1050	34.4	23.8	0.69	2.44	42.7	14.1	3.2
	7.0	1.8	4.2	1050	46.8	2.95	36.7	111.2	4.65	6.0	1250	48.4	2.90	38.6	105.9	4.90	5.5	1050	35.7	26.5	0.74	2.51	44.3	14.2	3.4
	9.0	2.8	6.5	1050	48.2	2.99	38.0	112.5	4.73	6.1	1250	49.9	2.92	40.0	107.0	5.01	5.7	1050	35.3	24.1	0.68	2.35	43.3	15.0	3.0
100	5.0	1.0	2.3	Operation not recommended							Operation not recommended														
	7.0	1.7	4.0	Operation not recommended							Operation not recommended														
	9.0	2.7	6.2	1050	46.7	2.80	37.1	104.6	4.88	5.1	1250	48.4	2.90	38.6	105.9	4.90	5.5	1050	32.2	23.3	0.72	2.85	41.9	11.3	4.7
110	5.0	1.0	2.2	Operation not recommended							Operation not recommended														
	7.0	1.7	3.9	Operation not recommended							Operation not recommended														
	9.0	2.6	6.0	1050	46.7	2.80	37.1	104.6	4.88	5.1	1250	48.4	2.90	38.6	105.9	4.90	5.5	1050	32.6	23.2	0.71	2.80	42.1	11.6	4.3
120	5.0	0.9	2.1	Operation not recommended							Operation not recommended														
	7.0	1.6	3.7	Operation not recommended							Operation not recommended														
	9.0	2.5	5.8	1050	46.7	2.80	37.1	104.6	4.88	5.1	1250	48.4	2.90	38.6	105.9	4.90	5.5	1050	27.7	21.4	0.77	3.48	39.6	8.0	6.8

Multiple Flow Rates (for EWT) are shown in the table above. The lowest flow rate shown is used for geothermal open loop/well water systems with a minimum 50° F. The second flow rate shown is the minimum geothermal closed loop flow rate. The third flow rate shown is optimum for geothermal closed loop and the suggested flow rate for boiler tower applications.

NDS049 - Performance Data

Low Speed (1350CFM)

EWT °F	Flow gpm	WPD		HEATING - EAT 70°F							COOLING - EAT 80/67 °F														
		PSI	FT	Airflow cfm	HC kBtuh	Power kW	HE kBtuh	LAT °F	COP	HWC kBtuh	Airflow cfm	TC kBtuh	SC kBtuh	S/T Ratio	Power kW	HR kBtuh	EER	HWC kBtuh							
20	5.0	0.9	2.2	Operation not recommended							Operation not recommended														
	8.0	2.0	4.6	Operation not recommended							Operation not recommended														
	11.0	3.4	7.8	1150	22.2	2.05	15.2	87.9	3.17	4.1	1350	23.0	2.08	15.9	85.8	3.24	3.7								
30	5.0	0.9	2.1	Operation not recommended							Operation not recommended														
	8.0	1.9	4.4	1150	25.6	2.09	18.4	90.6	3.58	4.2	1350	26.3	2.10	19.2	88.1	3.67	3.8	1150	35.0	20.6	0.59	1.18	39.1	29.7	-
	11.0	3.3	7.6	1150	26.2	2.10	19.0	91.1	3.65	4.3	1350	27.1	2.13	19.8	88.6	3.73	3.9	1150	35.1	20.5	0.58	1.10	38.9	31.9	-
40	5.0	0.9	2.0	Operation not recommended							Operation not recommended														
	8.0	1.9	4.3	1150	29.3	2.16	21.9	93.6	3.97	4.5	1350	30.4	2.16	23.0	90.8	4.11	4.1	1150	37.0	22.5	0.61	1.30	41.5	28.5	-
	11.0	3.2	7.4	1150	30.3	2.18	22.9	94.4	4.07	4.6	1350	31.3	2.19	23.8	91.5	4.18	4.2	1150	37.2	22.4	0.60	1.22	41.3	30.5	-
50	5.0	0.9	2.0	1150	30.4	2.16	23.0	94.5	4.13	4.7	1350	31.4	2.16	24.0	91.5	4.26	4.3	1150	37.8	24.0	0.64	1.68	43.5	22.5	1.6
	8.0	1.8	4.2	1150	32.8	2.23	25.1	96.4	4.31	4.8	1350	34.0	2.21	26.4	93.3	4.50	4.4	1150	38.9	28.3	0.73	1.75	44.9	22.2	1.6
	11.0	3.1	7.2	1150	34.0	2.24	26.4	97.4	4.44	5.0	1350	35.1	2.24	27.5	94.1	4.59	4.5	1150	38.6	24.1	0.62	1.45	43.5	26.5	1.4
60	5.0	0.8	1.9	1150	33.2	2.24	25.6	96.7	4.34	5.1	1350	34.4	2.23	26.8	93.6	4.53	4.8	1150	39.8	28.4	0.71	1.52	45.0	26.1	1.6
	8.0	1.8	4.0	1150	35.9	2.32	28.0	98.9	4.54	5.7	1350	37.3	2.29	29.5	95.6	4.77	5.3	1150	38.2	24.1	0.63	1.61	43.7	23.8	2.0
	11.0	3.0	6.9	1150	37.5	2.32	29.5	100.2	4.74	5.5	1350	38.8	2.29	31.0	96.6	4.96	5.0	1150	39.4	28.4	0.72	1.68	45.1	23.4	2.2
70	5.0	0.8	1.8	1150	33.2	2.24	25.6	96.7	4.34	5.1	1350	34.4	2.23	26.8	93.6	4.53	4.8	1150	37.6	24.0	0.64	1.81	43.7	20.8	2.2
	8.0	1.7	3.9	1150	35.9	2.32	28.0	98.9	4.54	5.7	1350	37.3	2.29	29.5	95.6	4.77	5.3	1150	38.8	28.2	0.73	1.89	45.2	20.5	2.3
	11.0	2.9	6.7	1150	37.5	2.32	29.5	100.2	4.74	5.5	1350	38.8	2.29	31.0	96.6	4.96	5.0	1150	38.2	24.1	0.63	1.61	43.7	23.8	2.0
80	5.0	0.8	1.8	1150	38.1	2.38	30.0	100.7	4.70	6.4	1350	39.6	2.34	31.6	97.2	4.97	5.9	1150	38.6	24.2	0.63	1.52	43.8	25.3	1.9
	8.0	1.6	3.8	1150	41.4	2.40	33.2	103.3	5.05	6.6	1350	43.1	2.34	35.1	99.5	5.39	6.1	1150	37.8	28.5	0.72	1.59	45.2	25.0	2.1
	11.0	2.8	6.5	1150	43.5	2.43	35.2	105.0	5.25	6.8	1350	45.3	2.36	37.2	101.0	5.61	6.2	1150	39.8	28.5	0.72	1.59	45.2	25.0	2.1
90	5.0	0.7	1.7	1150	40.2	2.43	31.9	102.4	4.85	7.1	1350	41.8	2.38	33.7	98.7	5.16	6.6	1150	36.6	24.1	0.66	2.17	44.0	16.8	4.3
	8.0	1.6	3.6	1150	43.7	2.44	35.4	105.2	5.25	7.3	1350	45.5	2.36	37.5	101.2	5.65	6.8	1150	37.7	28.3	0.75	2.27	45.5	16.6	4.5
	11.0	2.7	6.2	1150	46.1	2.47	37.7	107.1	5.48	7.5	1350	48.1	2.39	39.9	103.0	5.90	7.0	1150	36.8	24.4	0.66	2.02	43.7	18.2	4.0
100	5.0	0.7	1.7	Operation not recommended							Operation not recommended														
	8.0	1.5	3.5	Operation not recommended							Operation not recommended														
	11.0	2.6	6.0	1150	43.5	2.43	35.2	105.0	5.25	6.8	1350	45.3	2.36	37.2	101.0	5.61	6.2	1150	37.9	28.7	0.76	2.10	45.0	18.0	4.3
110	5.0	0.7	1.6	Operation not recommended							Operation not recommended														
	8.0	1.5	3.4	Operation not recommended							Operation not recommended														
	11.0	2.5	5.8	1150	43.7	2.44	35.4	105.2	5.25	7.3	1350	45.5	2.36	37.5	101.2	5.65	6.8	1150	37.6	24.6	0.65	1.93	44.2	19.5	3.7
120	5.0	0.7	1.5	Operation not recommended							Operation not recommended														
	8.0	1.4	3.3	Operation not recommended							Operation not recommended														
	11.0	2.4	5.6	1150	27.2	2.12	18.4	90.6	3.58	4.2	1350	28.2	2.12	19.2	88.1	3.67	3.8	1150	37.6	24.0	0.64	1.81	43.7	20.8	2.2

Multiple Flow Rates (for EWT) are shown in the table above. The lowest flow rate shown is used for geothermal open loop/well water systems with a minimum 50° F. The second flow rate shown is the minimum geothermal closed loop flow rate. The third flow rate shown is optimum for geothermal closed loop and the suggested flow rate for boiler tower applications.

NDS049 - Performance Data

High Speed (1550CFM)

EWT °F	Flow gpm	WPD		HEATING - EAT 70°F							COOLING - EAT 80/67 °F														
		PSI	FT	Airflow cfm	HC kBtuh	Power kW	HE kBtuh	LAT °F	COP	HWC kBtuh	Airflow cfm	TC kBtuh	SC kBtuh	S/T Ratio	Power kW	HR kBtuh	EER	HWC kBtuh							
20	6.0	1.3	3.0	Operation not recommended							Operation not recommended														
	9.0	2.5	5.7	Operation not recommended							Operation not recommended														
	12.0	4.0	9.2	1350	30.7	2.74	21.3	91.0	3.28	5.2	1550	31.7	2.82	22.1	88.9	3.29	4.7								
30	6.0	1.2	2.9	Operation not recommended							Operation not recommended														
	9.0	2.4	5.5	1350	35.0	2.87	25.2	94.0	3.58	5.5	1550	36.1	2.96	26.0	91.5	3.57	5.1	1350	46.3	28.5	0.62	1.90	52.8	24.4	-
	12.0	3.9	8.9	1350	35.5	2.90	25.6	94.4	3.60	5.7	1550	36.7	2.99	26.5	91.9	3.60	5.2	1350	46.8	28.5	0.61	1.81	53.0	25.9	-
40	6.0	1.2	2.8	Operation not recommended							Operation not recommended														
	9.0	2.3	5.3	1350	39.9	3.00	29.7	97.4	3.90	6.1	1550	41.1	3.06	30.6	94.5	3.93	5.6	1350	48.0	30.2	0.63	2.10	55.2	22.9	-
	12.0	3.7	8.7	1350	40.6	3.03	30.3	97.9	3.93	6.3	1550	42.0	3.09	31.4	95.1	3.97	5.7	1350	48.6	30.2	0.62	2.01	55.4	24.2	-
50	6.0	1.2	2.7	1350	42.7	3.10	32.1	99.3	4.03	6.6	1550	44.1	3.14	33.3	96.3	4.11	6.1	1350	48.6	31.0	0.64	2.50	57.2	19.4	2.9
	9.0	2.2	5.2	1350	44.4	3.16	33.6	100.4	4.11	6.8	1550	45.6	3.21	34.7	97.3	4.17	6.2	1350	49.2	31.4	0.64	2.35	57.2	21.0	2.7
	12.0	3.6	8.4	1350	45.2	3.20	34.3	101.0	4.15	7.0	1550	46.7	3.24	35.7	97.9	4.23	6.4	1350	49.7	31.5	0.63	2.26	57.4	22.0	2.5
60	6.0	1.1	2.6	1350	46.6	3.23	35.6	102.0	4.23	7.4	1550	48.1	3.24	37.0	98.7	4.34	6.8	1350	48.1	31.3	0.65	2.66	57.1	18.1	3.6
	9.0	2.2	5.0	1350	48.7	3.31	37.4	103.4	4.31	7.6	1550	50.2	3.33	38.8	100.0	4.42	7.0	1350	50.4	34.7	0.69	2.78	59.9	18.2	3.8
	12.0	3.5	8.1	1350	49.8	3.35	38.4	104.2	4.36	7.8	1550	51.4	3.36	40.0	100.7	4.49	7.2	1350	48.9	31.7	0.65	2.51	57.4	19.5	3.3
70	6.0	1.1	2.5	1350	50.4	3.34	39.0	104.6	4.42	8.3	1550	52.0	3.33	40.6	101.1	4.57	7.7	1350	49.4	31.8	0.65	2.43	57.7	20.3	3.1
	9.0	2.1	4.9	1350	52.9	3.44	41.2	106.3	4.50	8.6	1550	54.6	3.43	42.8	102.6	4.66	7.9	1350	51.8	34.9	0.67	2.46	60.2	21.0	2.9
	12.0	3.4	7.9	1350	54.3	3.49	42.4	107.2	4.56	8.8	1550	56.0	3.47	44.2	103.5	4.73	8.1	1350	49.7	31.5	0.63	2.26	57.4	22.0	2.5
80	6.0	1.1	2.5	1350	53.5	3.52	41.5	106.7	4.45	9.3	1550	55.2	3.48	43.4	103.0	4.65	8.6	1350	47.8	31.9	0.67	2.91	57.7	16.4	4.5
	9.0	2.0	4.7	1350	56.5	3.65	44.0	108.7	4.54	9.6	1550	58.3	3.60	46.0	104.8	4.74	8.9	1350	49.9	35.4	0.71	3.01	60.2	16.6	4.7
	12.0	3.3	7.6	1350	58.1	3.69	45.5	109.8	4.62	9.9	1550	60.0	3.64	47.6	105.8	4.83	9.2	1350	48.8	32.3	0.66	2.77	58.3	17.7	4.2
90	6.0	1.0	2.4	1350	56.5	3.68	43.9	108.7	4.49	10.5	1550	58.4	3.61	46.1	104.9	4.74	9.7	1350	51.0	35.8	0.70	2.87	60.8	17.8	4.5
	9.0	2.0	4.5	1350	59.9	3.84	46.8	111.1	4.58	10.8	1550	61.9	3.76	49.1	107.0	4.83	10.0	1350	49.3	32.5	0.66	2.69	58.5	18.3	3.9
	12.0	3.2	7.3	1350	61.8	3.87	48.6	112.4	4.67	11.2	1550	63.9	3.80	50.9	108.2	4.92	10.3	1350	51.6	36.1	0.70	2.79	61.1	18.5	4.3
100	6.0	1.0	2.3	Operation not recommended							Operation not recommended														
	9.0	1.9	4.4	Operation not recommended							Operation not recommended														
	12.0	3.1	7.1	1350	42.3	29.6	0.70	3.65	54.8	11.6	8.2	1550	43.7	32.7	0.75	3.70	56.3	11.8	8.9						
110	6.0	1.0	2.2	Operation not recommended							Operation not recommended														
	9.0	1.8	4.2	Operation not recommended							Operation not recommended														
	12.0	2.9	6.8	1350	38.2	27.6	0.72	3.97	51.8	9.6	10.0	1550	39.3	30.5	0.78	4.00	52.9	9.8	10.9						
120	6.0	0.9	2.1	Operation not recommended							Operation not recommended														
	9.0	1.7	4.0	Operation not recommended							Operation not recommended														
	12.0	2.8	6.5	1350	38.6	28.0	0.72	3.92	52.0	9.9	9.3	1550	39.7	31.0	0.78	3.95	53.2	10.0	10.4						

Multiple Flow Rates (for EWT) are shown in the table above. The lowest flow rate shown is used for geothermal open loop/well water systems with a minimum 50° F. The second flow rate shown is the minimum geothermal closed loop flow rate. The third flow rate shown is optimum for geothermal closed loop and the suggested flow rate for boiler tower applications.

NDS064 - Performance Data

Low Speed (1500CFM)

EWT °F	Flow gpm	WPD		HEATING - EAT 70°F							COOLING - EAT 80/67 °F														
		PSI	FT	Airflow cfm	HC kBtuh	Power kW	HE kBtuh	LAT °F	COP	HWC kBtuh	Airflow cfm	TC kBtuh	SC kBtuh	S/T Ratio	Power kW	HR kBtuh	EER	HWC kBtuh							
20	6.0	1.0	2.4	Operation not recommended							Operation not recommended														
	10.0	2.7	6.2	Operation not recommended							Operation not recommended														
	14.0	5.1	11.8	1250	25.8	2.66	16.8	89.1	2.85	4.9	1500	26.7	2.69	17.5	86.5	2.91	4.4								
30	6.0	1.0	2.3	Operation not recommended							Operation not recommended														
	10.0	2.6	6.0	1250	30.0	2.74	20.6	92.2	3.21	4.9	1500	31.0	2.77	21.6	89.2	3.28	4.5	1250	45.9	27.0	0.59	1.42	50.8	32.2	-
	14.0	5.0	11.5	1250	31.0	2.74	21.7	93.0	3.32	5.1	1500	32.1	2.77	22.6	89.8	3.39	4.6	1250	46.0	26.9	0.59	1.39	50.8	33.1	-
40	6.0	1.0	2.3	Operation not recommended							Operation not recommended														
	10.0	2.5	5.9	1250	35.4	2.83	25.7	96.2	3.66	5.2	1500	36.3	2.84	26.6	92.4	3.75	4.8	1250	47.3	27.7	0.59	1.56	52.6	30.2	-
	14.0	4.8	11.1	1250	36.5	2.84	26.8	97.0	3.76	5.4	1500	37.5	2.85	27.8	93.1	3.85	4.9	1250	47.4	27.6	0.58	1.53	52.6	31.0	-
50	6.0	0.9	2.2	1250	39.8	2.88	30.0	99.5	4.05	5.5	1500	40.9	2.88	31.0	95.2	4.16	5.1	1250	48.4	28.0	0.58	1.81	54.6	26.7	1.8
	10.0	2.5	5.7	1250	40.4	2.93	30.4	99.9	4.04	5.7	1500	41.3	2.91	31.4	95.5	4.16	5.2	1250	48.5	28.3	0.58	1.75	54.5	27.8	1.7
	14.0	4.7	10.8	1250	41.6	2.95	31.6	100.8	4.14	5.8	1500	42.6	2.93	32.6	96.3	4.26	5.3	1250	48.7	28.3	0.58	1.71	54.5	28.4	1.5
60	6.0	0.9	2.1	1250	44.3	2.97	34.1	102.8	4.37	6.0	1500	45.2	2.95	35.2	97.9	4.50	5.6	1250	46.7	27.4	0.59	2.02	53.6	23.1	2.5
	10.0	2.4	5.5	1250	45.7	3.02	35.3	103.8	4.42	6.2	1500	46.4	2.98	36.2	98.6	4.56	5.7	1250	46.9	27.7	0.59	1.96	53.6	23.9	2.4
	14.0	4.5	10.4	1250	46.8	3.05	36.3	104.6	4.49	6.4	1500	47.5	3.01	37.2	99.3	4.63	5.9	1250	47.1	27.7	0.59	1.92	53.6	24.5	2.2
70	6.0	0.9	2.0	1250	48.7	3.07	38.2	106.0	4.65	6.7	1500	49.5	3.01	39.2	100.5	4.81	6.2	1250	48.5	27.8	0.61	2.29	53.7	20.1	3.6
	10.0	2.3	5.3	1250	50.7	3.12	40.1	107.6	4.77	6.9	1500	51.3	3.05	40.9	101.7	4.93	6.4	1250	46.1	28.0	0.61	2.22	53.7	20.8	3.3
	14.0	4.4	10.1	1250	51.7	3.15	40.9	108.3	4.81	7.1	1500	52.2	3.08	41.7	102.3	4.97	6.5	1250	47.6	31.5	0.66	2.32	55.5	20.5	3.6
80	6.0	0.9	2.0	1250	52.8	3.16	42.0	109.1	4.89	7.4	1500	53.2	3.09	42.7	102.9	5.05	6.9	1250	46.4	28.1	0.61	2.17	53.8	21.4	3.1
	10.0	2.2	5.1	1250	55.7	3.21	44.8	111.3	5.09	7.7	1500	56.0	3.12	45.4	104.6	5.27	7.1	1250	43.9	26.8	0.61	2.58	52.7	17.0	4.9
	14.0	4.2	9.8	1250	56.4	3.25	45.3	111.8	5.08	7.9	1500	56.6	3.16	45.8	104.9	5.25	7.3	1250	45.2	29.9	0.66	2.67	54.3	16.9	5.2
90	6.0	0.8	1.9	1250	56.7	3.25	45.6	112.0	5.11	8.3	1500	56.9	3.17	46.1	105.1	5.26	7.7	1250	44.5	27.2	0.61	2.48	53.0	18.0	4.3
	10.0	2.1	5.0	1250	60.6	3.30	49.3	114.9	5.37	8.6	1500	60.6	3.18	49.7	107.4	5.57	8.0	1250	45.9	30.5	0.66	2.57	54.7	17.9	4.7
	14.0	4.1	9.4	1250	61.0	3.36	49.5	115.2	5.32	8.8	1500	60.8	3.24	49.8	107.5	5.51	8.2	1250	41.4	25.9	0.63	2.82	51.0	14.7	5.7
100	6.0	0.8	1.8	Operation not recommended							Operation not recommended														
	10.0	2.1	4.8	Operation not recommended							Operation not recommended														
	14.0	3.9	9.1	Operation not recommended							Operation not recommended														
110	6.0	0.8	1.8	Operation not recommended							Operation not recommended														
	10.0	2.0	4.6	Operation not recommended							Operation not recommended														
	14.0	3.8	8.7	Operation not recommended							Operation not recommended														
120	6.0	0.7	1.7	Operation not recommended							Operation not recommended														
	10.0	1.9	4.4	Operation not recommended							Operation not recommended														
	14.0	3.6	8.4	Operation not recommended							Operation not recommended														

Multiple Flow Rates (for EWT) are shown in the table above. The lowest flow rate shown is used for geothermal open loop/well water systems with a minimum 50° F. The second flow rate shown is the minimum geothermal closed loop flow rate. The third flow rate shown is optimum for geothermal closed loop and the suggested flow rate for boiler tower applications.

NDS064 - Performance Data

High Speed (1800CFM)

EWT °F	Flow gpm	WPD		HEATING - EAT 70°F							COOLING - EAT 80/67 °F												
		PSI	FT	Airflow cfm	HC kBtuh	Power kW	HE kBtuh	LAT °F	COP	HWC kBtuh	Airflow cfm	TC kBtuh	SC kBtuh	S/T Ratio	Power kW	HR kBtuh	EER	HWC kBtuh					
20	8.0	1.8	4.2	Operation not recommended							Operation not recommended												
	12.0	3.8	8.8	Operation not recommended							Operation not recommended												
	16.0	6.5	15.1	1500	38.2	3.68	25.7	93.6	3.04	6.0	1800	39.2	3.85	26.0	90.1	2.98	5.4						
30	8.0	1.8	4.1	Operation not recommended							Operation not recommended												
	12.0	3.7	8.6	1500	44.1	3.69	31.5	97.2	3.50	6.3	1500	57.9	37.0	0.64	2.32	65.8	24.9	-					
				1800	45.3	3.93	31.9	93.3	3.38	5.8	1800	58.4	40.3	0.69	2.47	66.8	23.7	-					
	16.0	6.4	14.7	1500	44.7	3.79	31.8	97.6	3.46	6.5	1500	58.5	37.4	0.64	2.28	66.3	25.6	-					
			1800	45.8	3.97	32.2	93.5	3.38	5.9	1800	58.9	40.6	0.69	2.43	67.2	24.3	-						
40	8.0	1.7	4.0	Operation not recommended							Operation not recommended												
	12.0	3.6	8.3	1500	50.7	3.94	37.3	101.3	3.77	7.0	1500	60.2	38.0	0.63	2.67	69.3	22.5	-					
				1800	51.9	4.11	37.9	96.7	3.70	6.4	1800	61.1	41.4	0.68	2.83	70.7	21.6	-					
	16.0	6.2	14.2	1500	51.5	4.01	37.8	101.8	3.76	7.2	1500	60.8	38.4	0.63	2.62	69.7	23.2	-					
			1800	52.7	4.15	38.5	97.1	3.72	6.5	1800	61.6	41.7	0.68	2.79	71.1	22.1	-						
50	8.0	1.7	3.8	1500	54.1	4.10	40.1	103.4	3.87	7.5	1500	61.1	38.3	0.63	3.12	71.8	19.6	3.4					
				1800	55.3	4.23	40.8	98.4	3.83	7.0	1800	62.4	41.7	0.67	3.32	73.7	18.8	3.6					
	12.0	3.5	8.1	1500	57.2	4.18	43.0	105.3	4.01	7.8	1500	61.8	38.7	0.63	3.06	72.2	20.2	3.2					
				1800	58.4	4.29	43.8	100.0	3.99	7.1	1800	63.0	42.1	0.67	3.25	74.1	19.4	3.5					
	16.0	6.0	13.8	1500	58.2	4.23	43.8	105.9	4.03	8.0	1500	62.4	39.1	0.63	3.00	72.6	20.8	3.0					
				1800	59.4	4.33	44.7	100.6	4.02	7.3	1800	63.6	42.4	0.67	3.19	74.5	19.9	3.3					
60	8.0	1.6	3.7	1500	60.7	4.38	45.7	107.5	4.06	8.5	1500	59.7	38.0	0.64	3.37	71.2	17.7	4.2					
				1800	62.0	4.46	46.8	101.9	4.08	7.8	1800	61.2	41.3	0.67	3.58	73.5	17.1	4.4					
	12.0	3.4	7.8	1500	63.5	4.46	48.3	109.2	4.18	8.7	1500	60.3	38.3	0.64	3.30	71.6	18.3	3.9					
				1800	64.8	4.51	49.4	103.4	4.21	8.0	1800	61.9	41.7	0.67	3.51	73.9	17.7	4.2					
	16.0	5.8	13.4	1500	64.8	4.51	49.5	110.0	4.22	9.0	1500	60.9	38.7	0.64	3.24	72.0	18.8	3.6					
				1800	66.3	4.56	50.8	104.1	4.27	8.2	1800	62.5	42.1	0.67	3.45	74.3	18.1	4.0					
70	8.0	1.6	3.6	1500	67.3	4.69	51.3	111.6	4.20	9.5	1500	60.2	38.3	0.64	3.74	73.0	16.1	5.2					
				1800	68.8	4.72	52.7	105.4	4.28	8.8	1800	62.1	41.6	0.67	3.99	75.7	15.6	5.5					
	12.0	3.3	7.5	1500	69.8	4.76	53.6	113.1	4.30	9.8	1500	60.8	38.7	0.64	3.67	73.4	16.6	4.9					
				1800	71.4	4.77	55.1	106.7	4.38	9.0	1800	62.8	42.0	0.67	3.90	76.1	16.1	5.3					
	16.0	5.6	12.9	1500	71.6	4.82	55.1	114.2	4.36	10.1	1500	61.4	39.1	0.64	3.61	73.7	17.0	4.5					
				1800	73.3	4.82	56.8	107.7	4.46	9.3	1800	63.4	42.5	0.67	3.84	76.5	16.5	5.0					
80	8.0	1.5	3.5	1500	74.0	5.00	56.9	115.7	4.34	10.7	1500	56.7	37.0	0.65	4.06	70.6	14.0	6.6					
				1800	75.7	4.97	58.7	108.9	4.46	9.9	1800	58.8	40.2	0.68	4.33	73.6	13.6	7.0					
	12.0	3.2	7.3	1500	75.7	5.06	58.5	116.8	4.39	11.0	1500	57.3	37.3	0.65	3.98	70.9	14.4	6.2					
				1800	77.5	5.01	60.4	109.9	4.54	10.2	1800	59.4	40.6	0.68	4.24	73.9	14.0	6.7					
	16.0	5.4	12.5	1500	78.0	5.12	60.6	118.2	4.46	11.4	1500	57.9	37.8	0.65	3.91	71.2	14.8	5.7					
				1800	80.0	5.06	62.7	111.1	4.63	10.5	1800	60.1	41.0	0.68	4.17	74.3	14.4	6.4					
90	8.0	1.4	3.3	1500	80.7	5.34	62.5	119.8	4.43	12.0	1500	52.2	35.7	0.68	4.35	67.0	12.0	8.3					
				1800	82.6	5.26	64.7	112.5	4.60	11.1	1800	54.5	38.7	0.71	4.64	70.3	11.8	8.8					
	12.0	3.0	7.0	1500	81.8	5.40	63.3	120.5	4.44	12.4	1500	52.8	36.0	0.68	4.27	67.4	12.4	7.7					
				1800	83.8	5.29	65.8	113.1	4.65	11.5	1800	55.0	39.1	0.71	4.54	70.5	12.1	8.4					
	16.0	5.2	12.0	1500	84.6	5.47	65.9	122.2	4.53	12.8	1500	53.3	36.4	0.68	4.19	67.6	12.7	7.2					
				1800	86.8	5.34	68.6	114.6	4.76	11.8	1800	55.6	39.5	0.71	4.47	70.9	12.4	8.0					
100	8.0	1.4	3.2	Operation not recommended							Operation not recommended												
	12.0	2.9	6.8	Operation not recommended							Operation not recommended												
	16.0	5.0	11.6	1500	51.3	35.1	0.68	4.71	67.4	10.9	9.6	1800	53.7	38.1	0.71	5.02	70.9	10.7	10.4				
			1500	51.8	35.5	0.68	4.63	67.6	11.2	8.9	1800	54.3	38.5	0.71	4.94	71.1	11.0	9.9					
110	8.0	1.3	3.1	Operation not recommended							Operation not recommended												
	12.0	2.8	6.5	Operation not recommended							Operation not recommended												
				1500	45.4	32.1	0.71	5.04	62.6	9.0	11.8	1800	47.8	34.8	0.73	5.38	66.2	8.9	12.8				
	16.0	4.8	11.2	1500	45.8	32.4	0.71	4.95	62.7	9.2	10.9	1800	48.2	35.2	0.73	5.29	66.3	9.1	12.1				
120	8.0	1.3	3.0	Operation not recommended							Operation not recommended												
	12.0	2.7	6.3	Operation not recommended							Operation not recommended												
				1500	44.2	32.6	0.74	5.56	63.1	7.9	14.2	1800	46.7	35.4	0.76	5.94	67.0	7.9	15.4				
	16.0	4.6	10.7	1500	44.6	33.0	0.74	5.46	63.2	8.2	13.2	1800	47.1	35.8	0.76	5.84	67.1	8.1	14.7				

Multiple Flow Rates (for EWT) are shown in the table above. The lowest flow rate shown is used for geothermal open loop/well water systems with a minimum 50° F. The second flow rate shown is the minimum geothermal closed loop flow rate. The third flow rate shown is optimum for geothermal closed loop and the suggested flow rate for boiler tower applications.

NDS072 Low Speed

1700 CFM Rated Airflow

EWT °F	Flow gpm	WPD		HEATING - EAT 70°F							COOLING - EAT 80/67 °F														
		PSI	FT	Airflow cfm	HC kBtuh	Power kW	HE kBtuh	LAT °F	COP	HWC kBtuh	Airflow cfm	TC kBtuh	SC kBtuh	S/T Ratio	Power kW	HR kBtuh	EER	HWC kBtuh							
20	10.0	2.3	5.4	Operation not recommended							Operation not recommended														
	13.0	3.6	8.2	Operation not recommended							Operation not recommended														
	16.0	5.0	11.6	1400	31.5	3.37	20.0	90.8	2.74	5.8	1700	33.0	3.41	21.4	88.0	2.84	5.3								
30	10.0	2.3	5.3	Operation not recommended							Operation not recommended														
	13.0	3.5	8.0	1400	35.2	3.39	23.6	93.3	3.04	5.9	1700	36.9	3.43	25.2	90.1	3.15	5.4	1400	49.5	30.2	0.61	1.79	55.6	27.6	-
	16.0	4.9	11.3	1400	36.7	3.39	25.2	94.3	3.17	6.1	1700	38.5	3.43	26.7	90.9	3.28	5.5	1400	49.5	30.2	0.61	1.72	55.4	28.7	-
40	10.0	2.2	5.1	Operation not recommended							Operation not recommended														
	13.0	3.4	7.8	1400	41.4	3.49	29.5	97.4	3.47	6.3	1700	43.2	3.50	31.2	93.5	3.62	5.8	1400	51.7	32.0	0.62	1.97	58.4	26.3	-
	16.0	4.7	11.0	1400	42.8	3.50	30.9	98.3	3.59	6.5	1700	44.7	3.51	32.7	94.4	3.73	5.9	1400	51.8	32.0	0.62	1.91	58.3	27.2	-
50	10.0	2.1	4.9	1400	46.2	3.53	34.2	100.6	3.84	6.6	1700	48.3	3.49	36.4	96.3	4.05	6.1	1400	53.6	33.4	0.62	2.27	61.3	23.6	2.0
	13.0	3.3	7.5	1400	46.9	3.57	34.8	101.0	3.85	6.8	1700	48.8	3.55	36.7	96.6	4.03	6.3	1400	53.7	33.7	0.63	2.19	61.2	24.5	1.9
	16.0	4.6	10.6	1400	48.3	3.59	36.1	101.9	3.94	7.0	1700	50.4	3.57	38.2	97.4	4.13	6.4	1400	53.9	33.7	0.63	2.13	61.1	25.3	1.8
60	10.0	2.1	4.8	1400	51.4	3.64	39.0	104.0	4.13	7.3	1700	53.6	3.57	41.4	99.2	4.40	6.7	1400	52.0	33.0	0.63	2.49	60.5	20.9	2.9
	13.0	3.2	7.3	1400	52.9	3.68	40.3	105.0	4.21	7.5	1700	55.0	3.62	42.6	99.9	4.45	6.9	1400	52.3	33.3	0.64	2.41	60.5	21.7	2.7
	16.0	4.4	10.3	1400	54.1	3.72	41.4	105.8	4.26	7.7	1700	56.2	3.65	43.8	100.6	4.51	7.1	1400	52.5	33.4	0.64	2.37	60.5	22.2	2.5
70	10.0	2.0	4.6	1400	56.7	3.77	43.8	107.5	4.40	8.0	1700	59.0	3.66	46.5	102.1	4.72	7.4	1400	51.7	33.5	0.65	2.79	61.2	18.5	4.0
	13.0	3.0	7.0	1400	58.9	3.81	45.8	108.9	4.52	8.3	1700	61.2	3.70	48.5	103.3	4.84	7.7	1400	52.0	33.9	0.65	2.70	61.2	19.3	3.8
	16.0	4.3	9.9	1400	59.9	3.87	46.7	109.6	4.54	8.5	1700	62.2	3.76	49.4	103.9	4.86	7.9	1400	52.3	34.1	0.65	2.66	61.3	19.6	3.5
80	10.0	1.9	4.5	1400	61.1	3.87	47.9	110.4	4.63	9.0	1700	63.3	3.73	50.6	104.5	4.97	8.3	1400	49.3	32.7	0.66	3.10	59.9	15.9	5.6
	13.0	2.9	6.8	1400	64.3	3.92	50.9	112.5	4.81	9.2	1700	66.6	3.76	53.8	106.3	5.19	8.5	1400	49.7	33.1	0.67	3.02	60.0	16.4	5.2
	16.0	4.2	9.6	1400	65.0	3.97	51.5	113.0	4.80	9.5	1700	67.3	3.82	54.2	106.6	5.16	8.8	1400	50.1	33.3	0.67	2.98	60.2	16.8	4.8
90	10.0	1.9	4.3	1400	65.6	3.99	52.0	113.4	4.82	10.0	1700	67.8	3.82	54.7	106.9	5.20	9.3	1400	45.5	31.1	0.68	3.45	57.3	13.2	7.4
	13.0	2.8	6.6	1400	69.8	4.04	56.0	116.2	5.07	10.3	1700	72.2	3.84	59.1	109.3	5.51	9.6	1400	46.0	31.4	0.68	3.38	57.5	13.6	6.9
	16.0	4.0	9.3	1400	70.3	4.10	56.3	116.5	5.03	10.6	1700	72.5	3.91	59.1	109.5	5.43	9.9	1400	46.5	31.7	0.68	3.32	57.8	14.0	6.4
100	10.0	1.8	4.2	Operation not recommended							Operation not recommended														
	13.0	2.7	6.3	Operation not recommended							Operation not recommended														
	16.0	3.9	8.9	1400	44.1	3.13	0.71	3.82	57.1	11.6	9.0	1700	45.5	34.7	0.76	3.86	58.7	11.8	9.8						
110	10.0	1.7	4.0	Operation not recommended							Operation not recommended														
	13.0	2.6	6.1	Operation not recommended							Operation not recommended														
	16.0	3.7	8.6	1400	39.2	29.4	0.75	4.26	53.7	9.2	11.4	1700	40.5	32.4	0.80	4.28	55.1	9.5	12.4						
120	10.0	1.7	3.8	Operation not recommended							Operation not recommended														
	13.0	2.5	5.8	Operation not recommended							Operation not recommended														
	16.0	3.6	8.2	1400	37.4	29.1	0.78	4.73	53.5	7.9	13.1	1700	38.4	31.9	0.83	4.72	54.5	8.1	14.6						

NDS072 High Speed

2200 CFM Rated Airflow

EWT °F	Flow gpm	WPD		HEATING - EAT 70°F							COOLING - EAT 80/67 °F							
		PSI	FT	Airflow cfm	HC kBtuh	Power kW	HE kBtuh	LAT °F	COP	HWC kBtuh	Airflow cfm	TC kBtuh	SC kBtuh	S/T Ratio	Power kW	HR kBtuh	EER	HWC kBtuh
20	12.0	3.3	7.6	Operation not recommended							Operation not recommended							
	15.0	4.6	10.7	Operation not recommended							Operation not recommended							
	18.0	6.2	14.3	1850 2200	44.0 45.7	4.15 4.41	29.9 30.6	92.0 89.2	3.11 3.03	7.7 6.9	Operation not recommended							
30	12.0	3.2	7.4	Operation not recommended							Operation not recommended							
	15.0	4.5	10.4	1850 2200	51.0 52.8	4.31 4.58	36.3 37.2	95.5 92.2	3.47 3.38	8.1 7.4	1850 2200	63.3 64.5	38.6 42.0	0.61 0.65	2.51 2.67	71.9 73.6	25.2 24.2	- -
	18.0	6.0	13.9	1850 2200	51.5 53.4	4.35 4.63	36.6 37.6	95.8 92.5	3.47 3.38	8.3 7.6	1850 2200	63.9 65.1	39.3 42.3	0.61 0.65	2.47 2.62	72.4 74.1	25.9 24.8	- -
40	12.0	3.1	7.1	Operation not recommended							Operation not recommended							
	15.0	4.4	10.1	1850 2200	59.2 61.2	4.57 4.79	43.6 44.9	99.6 95.8	3.79 3.74	8.9 8.2	1850 2200	65.8 67.1	41.1 44.7	0.62 0.67	3.03 3.22	76.2 78.1	21.7 20.8	- -
	18.0	5.8	13.5	1850 2200	60.0 62.1	4.63 4.84	44.2 45.6	100.0 96.1	3.80 3.76	9.2 8.4	1850 2200	66.5 67.8	41.9 45.1	0.63 0.66	2.98 3.17	76.7 78.6	22.3 21.4	- -
50	12.0	3.0	6.9	1850 2200	63.0 65.1	4.77 4.94	46.7 48.3	101.5 97.4	3.87 3.87	9.6 8.9	1850 2200	67.0 68.4	42.8 46.5	0.64 0.68	3.68 3.91	79.6 81.8	18.2 17.5	3.8 4.0
	15.0	4.2	9.8	1850 2200	66.5 68.7	4.86 5.02	50.0 51.6	103.3 98.9	4.02 4.02	9.9 9.1	1850 2200	67.7 69.1	43.2 47.0	0.64 0.68	3.61 3.83	80.0 82.1	18.8 18.0	3.5 3.8
	18.0	5.7	13.1	1850 2200	67.7 70.0	4.92 5.07	51.0 52.7	103.9 99.4	4.04 4.05	10.2 9.4	1850 2200	68.4 69.8	44.1 47.4	0.64 0.68	3.55 3.77	80.5 82.6	19.3 18.5	3.3 3.7
60	12.0	2.9	6.7	1850 2200	70.8 73.1	5.08 5.18	53.5 55.4	105.4 100.8	4.09 4.14	10.8 10.0	1850 2200	65.8 67.2	42.8 46.3	0.65 0.69	3.91 4.16	79.2 81.4	16.8 16.2	4.6 4.9
	15.0	4.1	9.5	1850 2200	74.0 76.4	5.17 5.25	56.3 58.4	107.0 102.1	4.20 4.26	11.2 10.3	1850 2200	66.5 67.8	43.3 46.8	0.65 0.69	3.83 4.07	79.6 81.7	17.4 16.7	4.3 4.7
	18.0	5.5	12.7	1850 2200	75.6 78.1	5.23 5.30	57.8 60.0	107.8 102.9	4.24 4.32	11.5 10.5	1850 2200	67.2 68.6	43.9 47.3	0.65 0.69	3.77 4.01	80.1 82.2	17.9 17.1	4.0 4.5
70	12.0	2.8	6.5	1850 2200	78.7 81.2	5.39 5.43	60.3 62.7	109.4 104.2	4.28 4.38	12.2 11.2	1850 2200	65.8 67.2	43.7 47.0	0.66 0.70	4.35 4.63	80.7 83.0	15.1 14.5	5.8 6.2
	15.0	4.0	9.1	1850 2200	81.5 84.1	5.48 5.49	62.8 65.4	110.8 105.4	4.36 4.49	12.5 11.6	1850 2200	66.4 67.8	44.1 47.4	0.66 0.70	4.26 4.53	81.0 83.3	15.6 15.0	5.4 5.9
	18.0	5.3	12.2	1850 2200	83.6 86.4	5.55 5.55	64.7 67.5	111.8 106.4	4.42 4.56	12.9 11.9	1850 2200	67.2 68.5	44.6 48.0	0.66 0.70	4.19 4.46	81.5 83.8	16.0 15.4	5.0 5.6
80	12.0	2.7	6.3	1850 2200	85.7 88.5	5.75 5.71	66.1 69.0	112.9 107.2	4.36 4.54	13.7 12.7	1850 2200	62.9 64.3	42.5 45.9	0.68 0.72	4.68 4.98	78.9 81.2	13.5 12.9	7.3 7.8
	15.0	3.8	8.8	1850 2200	87.7 90.5	5.83 5.75	67.8 70.9	113.9 108.1	4.41 4.61	14.1 13.0	1850 2200	63.6 64.9	42.9 46.4	0.68 0.71	4.58 4.87	79.2 81.5	13.9 13.3	6.9 7.4
	18.0	5.1	11.8	1850 2200	90.4 93.4	5.91 5.82	70.2 73.5	115.2 109.3	4.48 4.71	14.5 13.4	1850 2200	64.3 65.6	43.6 46.9	0.68 0.71	4.50 4.79	79.6 81.9	14.3 13.7	6.4 7.1
90	12.0	2.6	6.0	1850 2200	92.8 95.8	6.12 6.00	71.9 75.4	116.4 110.3	4.44 4.68	15.4 14.2	1850 2200	58.8 60.1	40.4 43.9	0.69 0.73	4.89 5.21	75.5 77.8	12.0 11.5	9.2 9.8
	15.0	3.7	8.5	1850 2200	94.1 97.1	6.19 6.03	73.0 76.6	117.1 110.9	4.45 4.72	15.8 14.7	1850 2200	59.4 60.6	40.8 44.3	0.69 0.73	4.79 5.10	75.7 78.0	12.4 11.9	8.6 9.3
	18.0	4.9	11.4	1850 2200	97.3 100.5	6.27 6.09	75.9 79.7	118.7 112.3	4.54 4.84	16.3 15.1	1850 2200	60.1 61.3	41.6 44.7	0.69 0.73	4.71 5.02	76.1 78.4	12.8 12.2	8.0 8.9
100	12.0	2.5	5.8	Operation not recommended							Operation not recommended							
	15.0	3.6	8.2	Operation not recommended							Operation not recommended							
	18.0	4.8	11.0	1850 2200	57.0 58.1	40.2 43.4	0.71 0.75	5.28 5.62	75.0 77.3	10.8 10.3	10.7 11.6	1850 2200	57.6 58.8	40.8 43.9	0.71 0.75	5.19 5.52	75.3 77.6	11.1 10.6
110	12.0	2.4	5.6	Operation not recommended							Operation not recommended							
	15.0	3.4	7.9	Operation not recommended							Operation not recommended							
	18.0	4.6	10.6	1850 2200	50.8 51.4	37.2 37.6	0.73 0.73	5.52 5.43	69.7 69.9	9.2 9.5	13.1 12.2	1850 2200	50.8 52.5	37.2 40.4	0.73 0.77	5.52 5.77	69.7 72.2	9.2 9.1
120	12.0	2.3	5.4	Operation not recommended							Operation not recommended							
	15.0	3.3	7.6	Operation not recommended							Operation not recommended							
	18.0	4.4	10.2	1850 2200	48.2 49.1	36.1 39.0	0.75 0.79	6.06 6.45	68.8 71.1	8.0 7.6	15.8 17.2	1850 2200	48.7 49.7	36.5 39.2	0.75 0.79	5.96 6.32	69.0 71.2	8.2 7.9

Wiring Schematics

Envision Series - Dual Capacity Split Wiring Schematic - 208-230/60/1

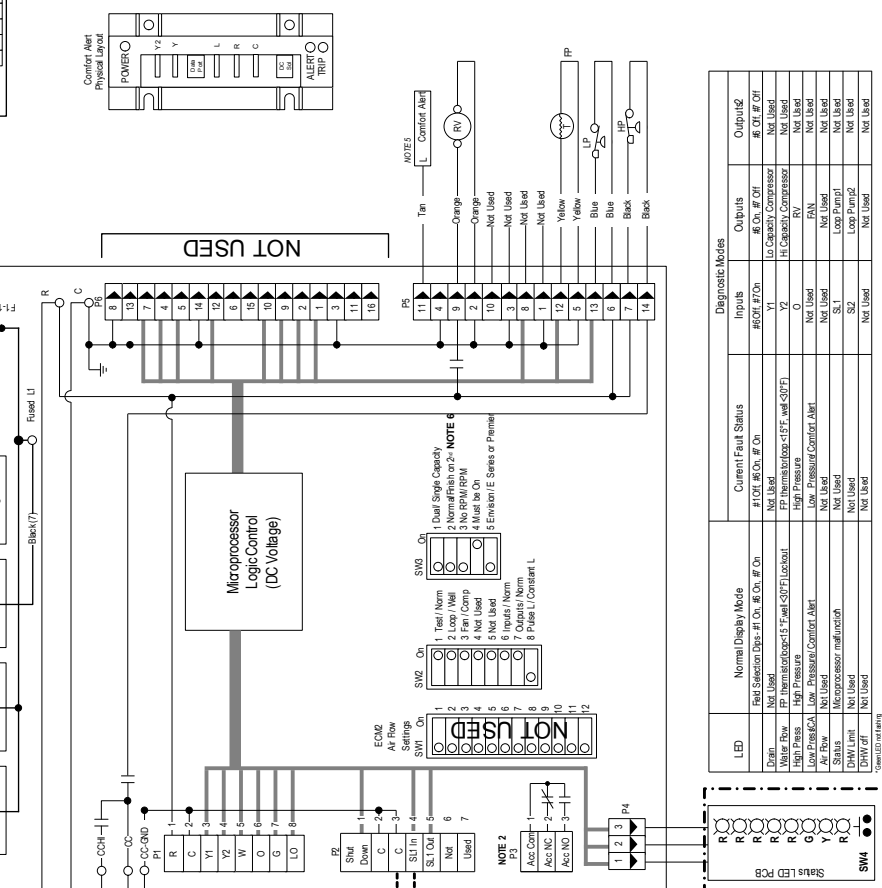
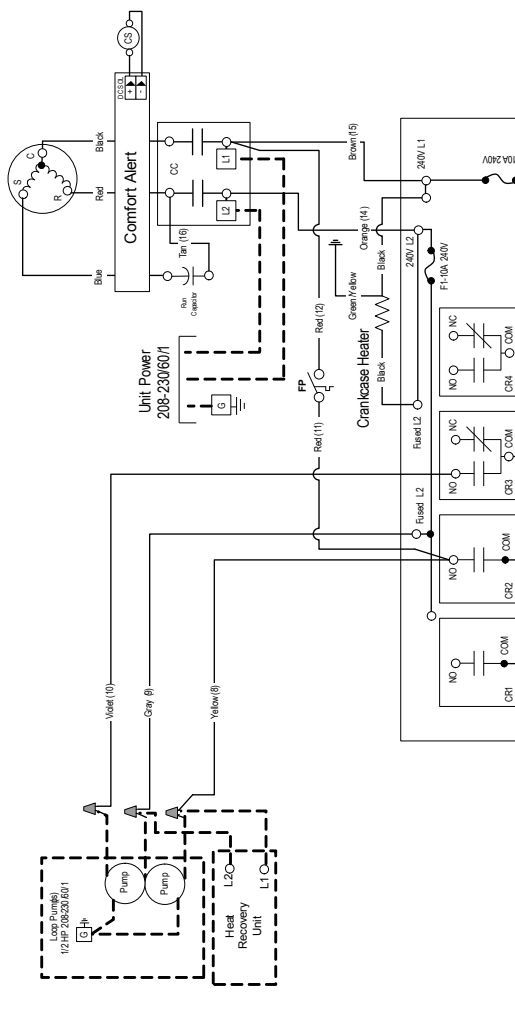
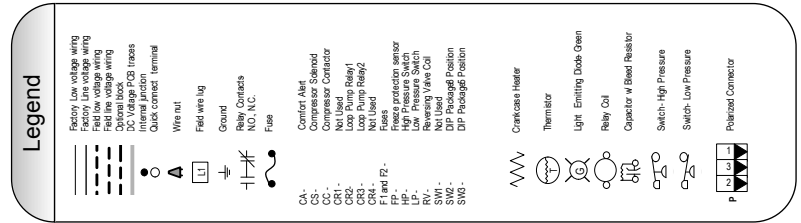
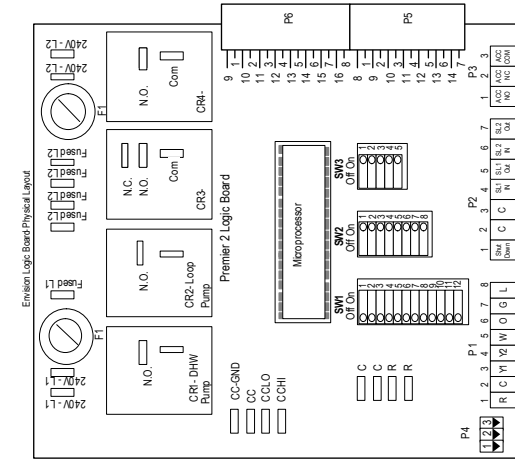

LED	Normal Display Mode	Current Fault Status	Inputs	Outputs
1	High Pressure	High Pressure	11	1
2	Low Pressure	Low Pressure	12	2
3	High Pressure	High Pressure	13	3
4	Low Pressure	Low Pressure	14	4
5	High Pressure	High Pressure	15	5
6	Low Pressure	Low Pressure	16	6
7	High Pressure	High Pressure	17	7
8	Low Pressure	Low Pressure	18	8
9	High Pressure	High Pressure	19	9
10	Low Pressure	Low Pressure	20	10
11	High Pressure	High Pressure	21	11
12	Low Pressure	Low Pressure	22	12
13	High Pressure	High Pressure	23	13
14	Low Pressure	Low Pressure	24	14
15	High Pressure	High Pressure	25	15
16	Low Pressure	Low Pressure	26	16
17	High Pressure	High Pressure	27	17
18	Low Pressure	Low Pressure	28	18
19	High Pressure	High Pressure	29	19
20	Low Pressure	Low Pressure	30	20
21	High Pressure	High Pressure	31	21
22	Low Pressure	Low Pressure	32	22
23	High Pressure	High Pressure	33	23
24	Low Pressure	Low Pressure	34	24
25	High Pressure	High Pressure	35	25
26	Low Pressure	Low Pressure	36	26
27	High Pressure	High Pressure	37	27
28	Low Pressure	Low Pressure	38	28
29	High Pressure	High Pressure	39	29
30	Low Pressure	Low Pressure	40	30
31	High Pressure	High Pressure	41	31
32	Low Pressure	Low Pressure	42	32
33	High Pressure	High Pressure	43	33
34	Low Pressure	Low Pressure	44	34
35	High Pressure	High Pressure	45	35
36	Low Pressure	Low Pressure	46	36
37	High Pressure	High Pressure	47	37
38	Low Pressure	Low Pressure	48	38
39	High Pressure	High Pressure	49	39
40	Low Pressure	Low Pressure	50	40

Notes

1. Connection of terminals will be done with a 300V crimping tool for wire size 18-22.
2. 300V crimping tool (see 208-230/60/1 for description of operation).
3. 300V crimping tool (see 208-230/60/1 for description of operation).
4. 300V crimping tool (see 208-230/60/1 for description of operation).
5. Comfort Alert LED output to Pump Control Board.
6. This table lists the unit's diagnostic modes with the state they will be in when the unit is powered up. The unit will be in the state shown in the table when the unit is powered up. The unit will be in the state shown in the table when the unit is powered up.

Microprocessor Control Features and Operation

The NS control system is a microprocessor-based printed circuit board conveniently located in the unit control box for easy accessibility. The microprocessor control is specifically designed for the Envision Series heat pumps. The microprocessor provides control of the entire unit as well as outputs for status modes, faults, and diagnostics. Low voltage terminal strips provide all necessary terminals for field connections. An LED board is installed for quick diagnostics. The control offers optimal space conditioning. The board accepts traditional 24VAC thermostat inputs.

Startup

The unit will not operate until all the inputs and safety controls are checked for normal conditions. At first power-up, a four-minute delay is employed before the compressor is energized.

Component Sequencing Delays

Components are sequenced and delayed for optimum space conditioning performance.

Accessory Relay

An accessory relay on the control board allows for field connection of solenoid valves, electronic air cleaners, etc. The accessory relay has a normally open output and a normally closed output. The accessory relay is factory set to control the optional electronic air-cleaner.

Short Cycle Protection

The control employs a minimum "off" time of four minutes and a minimum "on" time of two minutes to provide for short cycle protection of the compressor.

Loop Pump Slaving Signals

A signal between multiple Envision Series control boards at the slave inputs and outputs (SL1 In and Out) will provide for remote control of the loop pump on any unit.

Shutdown Input

A 24VAC common signal to the "shutdown" input on the control board puts the unit into shutdown mode. Compressor, hot water pump and fan operation are suspended.

Safety Controls

The NS control receives separate signals for a high pressure switch for safety, a low pressure switch to prevent loss of charge damage, and a low suction temperature thermistor for freeze sensing. Upon a continuous 30-second measurement of the fault (immediate for high pressure), compressor operation is suspended (see Fault Retry), the appropriate lockout LED begins flashing, and an output signal (LO) is made available for connection to a "fault" LED at the thermostat.

Testing

The NS control allows service personnel to shorten most timing delays for faster diagnostics.

Fault Retry

All faults are retried twice before finally locking the unit out. The "fault retry" feature is designed to prevent nuisance service calls.

Diagnostics

The NS control board allows all inputs and outputs to be displayed on the LEDs for fast and simple control board diagnosis.

Heating Operation

Note: At first power up, a four-minute time delay is employed before the compressor is energized.

Heat, 1st Stage (Y1)

The compressor and loop pumps are energized 10 seconds after the Y1 input.

Heat, 2nd Stage (Y1,Y2) Dual Capacity Units

The second stage compressor will be activated 5 seconds after receiving a "Y2" input as long as the minimum first stage compressor run time of 1 minute has expired.

The Comfort Alert will delay the second stage compressor until 5 seconds after it receives "Y2" from the board.

Cooling Operation

In all cooling operations, the reversing valve directly tracks the "O" input. Thus, anytime the "O" input is present, the reversing valve will be energized.

Cool, 1st Stage (Y1, O)

The compressor and loop pumps are energized 10 seconds after the Y1 input.

Cool, 2nd Stage (Y1, Y2, O) Dual Capacity Units

The second stage compressor will be activated 5 seconds after receiving a "Y2" input as long as the minimum first stage compressor run time of 1 minute has expired.

The Comfort Alert will delay the second stage compressor until 5 seconds after it receives a "Y2" from the board.

Fan Only Operation

The Fan Only mode is controlled directly from the unit thermostat to the unit air handler. No input is given to the microprocessor to operate the fan function.

Microprocessor Control Features...(cont.)

Lockout Conditions

During lockout mode, the appropriate thermostat lockout LEDs (if available) will illuminate. The compressor and loop pumps are de-energized and if the thermostat calls for third stage heating, emergency heat operation will occur.

Lockout modes of any kind can be reset at the thermostat after a 5-second waiting period, which restores normal operation.

High Pressure

This lockout mode occurs immediately when the normally closed safety switch is momentarily opened.

Low Pressure

This lockout mode occurs when the normally closed switch is opened for 30 continuous seconds.

Freeze Sensing (Water Flow)

This lockout mode occurs when the freeze sensing thermistor temperature (located between the TXV and coax) is at or below the selected freeze sensing point (well 30°F or loop 15°F) for 30 continuous seconds.

The unit also contains a secondary freeze sensing sensor located on the entering water line of the unit. If the loop reaches a temperature of 20°F the secondary freeze sensing sensor will cycle the loop pumps "on" until the loop temperature rises to or above 25°F.

Logic Board - Dual Capacity



Dual Capacity Operation Logic

OPERATION	HEATING			COOLING	
	STG1	STG2	STG3	STG1	STG2*
Compressor-Low	On	Off	Off	On	Off
Compressor-Hi	Off	On	Off	Off	On
Fan	On	On	On	On	On
Loop Pump	On	On	Off	On	On
Reversing Valve	Off	Off	Off	On	On
T-Stat Signal	Y1	Y1, Y2	W	Y1, O	Y1, Y2, O

Engineering Guide Specifications

General

The geothermal heating/cooling units shall be reverse cycle split system configuration designed for use with DX heating and cooling coils. Units shall be ARI/ISO Standard 13256-1 performance certified and listed by a nationally recognized safety-testing laboratory or agency, such as ETL Testing Laboratory. Each unit shall be computer run-tested at the factory. Each unit shall be mounted on a pallet and stretch-wrapped.

The geothermal units shall be designed to operate with entering liquid temperature between 25°F and 110°F as manufactured by WFI, of Fort Wayne, Indiana.

Casing & Cabinet

The cabinet shall be fabricated from heavy-gauge steel and finished with corrosion-resistant powder coating. The interior shall be insulated with 1/2-inch thick, multi-density, coated glass fiber.

Refrigerant Circuit

All units shall contain a sealed refrigerant circuit including a hermetic motor-compressor, thermostatic expansion valve, reversing valve, coaxial tube water-to-refrigerant heat exchanger, and service ports.

Compressors shall be high-efficiency Ultratech Scroll dual capacity type designed for heat pump duty and mounted on rubber vibration isolators. Compressor motors shall be single-phase PSC with overload protection.

The coaxial water-to-refrigerant heat exchanger shall be designed for low water pressure drop and constructed of a convoluted cupronickel inner tube and a steel outer tube.

The thermostatic expansion valve shall provide proper superheat over the entire liquid temperature range with minimal "hunting".

The water-to-refrigerant heat exchanger and refrigerant suction lines shall be insulated to prevent condensation at low liquid temperatures.

Electrical

The control shall provide operational sequencing, high- and low-pressure switch monitoring, lockout mode control, and loop pump control.

A terminal block with screw terminals will be provided for field control wiring. All units shall have knockouts for entrance of low and line voltage wiring.

Piping

Supply and return water connections shall be GeoLink swivel fittings which will connect to optional GeoLink loop pump assembly or 3-way valves. All water piping shall be insulated to prevent condensation at low liquid temperatures.

Options & Accessories

Thermostat (field-installed)

A multi-stage auto-changeover electronic digital thermostat shall be provided. The thermostat shall offer three heating and two cooling stages with precise temperature control. An OFF-HEAT-AUTO-COOL-EMERG system switch, OFF-AUTO fan switch, and indicating LEDs shall be provided. The thermostat shall display in °F or °C. An optional remote outdoor sensor shall be available.

Accessory Relay (field-installed)

An additional low-voltage accessory control relay shall be provided. This SPDT relay shall be capable of operation with any thermostat signal (Y1, O, L). The relay shall be located on a factory-provided mount in the unit low-voltage control wiring compartment.

Internally Mounted GeoLink Flow Center

1 or 2 pump flow center to connect to internally supplied fittings shall be available. Flush and fill fittings shall be available separately.

Decorative Rock Cover

For use with outdoor installations. (Specify brown granite, gray granite, salt & pepper, or charcoal basalt).



Manufactured by
WaterFurnace International, Inc.
9000 Conservation Way
Fort Wayne, IN 46809



Product:	Envision Series - NS Outdoor Split
Type:	Geothermal/Water Source Heat Pumps
Size:	2-6 Tons
Document:	Specification Catalog